

INSTITUTTET FOR HUSBYGNING

Forelæsningsnotat nr. **40**

KLAUS BLACH

HENRY W. HARRISON

JOHS. F. MUNCH-PETERSEN

GEOMETRY OF JOINTS

Den polytekniske Lærestalt, Danmarks tekniske Højskole

Lyngby 1975

Some notes on

GEOMETRY OF JOINTS

- for catalogue building

Klaus Blach
Harry W. Harrison
Johs. F. Munch-Petersen

FORORD

Geometry of Joints (Sammenbygningsprincipper for byggekomponenter) er udarbejdet på initiativ af CIB Programme Committee og International Modular Group.

Med hovedvægten lagt på geometriske forhold bringer notatet en systematisk oversigt over sammenbygningsprincipper for byggekomponenter.

Det er tanken, at denne foreløbige publikation, efter at have været forelagt i IMG og CIB W24 (Modular Co-ordination) skal kunne udsendes som CIB-report. Det er yderligere tanken at anvende notatet som basis for en bedre koordinering af de arbejder, der allerede i en række lande er igang indenfor området.

Sideløbende med diskussionen af notatet på internationalt plan, gennemføres ved SBI en opgave, der bl.a. sigter mod præsentation af en udvidet udgave af Geometry of Joints på dansk.

Efter aftale med mine medforfattere,

Klaus Blach, M.A.A.
Statens Byggeforskningsinstitut

Formand for CIB W24/IMG
Medlem af CIB W60

Henry W. Harrison, Dip.ARch. RIBA
United Kingdom Building Research Establishment

Medlem af CIB W24
Medlem af CIB W60

vil dette notat også blive benyttet ved undervisningen i Husbygning på Danmarks tekniske Højskole, især på kursus 6504.

Januar 1975
Johs. F. Munch-Petersen
Professor
Instituttet for Husbygning

Formand for CIB W61
Medlem af CIB W24

INTRODUCTION

It is becoming generally acknowledged that more extensive use of prefabricated components obtained under open market conditions (catalogue building) will require a larger effort to be focussed on the subject of joints. The techniques of dimensional and modular co-ordination have enabled components to be made compatible so far as their co-ordinating dimensions are concerned but this is not enough. In practice, even modular components will not fit together unless a proper joint between them has been developed; the problem is even more acute if those components are supposed to be standard and usable in a great variety of situations.

The purpose of the present document is to establish principles upon which various national and international bodies can base future studies. There are not yet any ready made standard solutions, nor indeed categories of solutions, though some ideas which appear to be worth further development are included.

The establishment of conventions is a half-way house between principles and wholesale joint standardization, in that it should enable compatibility without needless uniformity to be achieved. It is particularly appropriate in the case of components obtained from different sources.

From previous studies it is clear that a single universal joint is not achievable, such is the great variety of designs necessary to satisfy widely diverging performance needs.

It is clear too that not all features of joints are equally suitable, nor indeed necessary, for standardization, but at the same time some discipline over jointing is necessary for the notion of catalogue building to become a reality.

That discipline should ideally be so devised as to assist the achievement of compatibility at the joints between catalogue components in respect of dimensions, profiles and all relevant functional requirements. A means to achieve compatibility between the dimensions critical to fit has been devised, and a master list of joint functions is available. But compatibility of edge profiles (and the dependence of profiles on functional needs) in the catalogue component context has been very inadequately studied. Thus the present paper concentrates on the geometry of joints. However, it should go without saying that the many other relevant performance requirements must be satisfied. In this connection check lists of performance requirements of the kind already tabled for consideration in ISO will be relevant.

The process of component and joint designs are closely inter-linked. The iterative nature is often such that decisions of principle for joint design will be decided in advance of decisions on specific components. Designs often have their own priorities evident from their title, eg 'load bearing', 'weathertight', etc.

Success depends in part on the designer setting out clearly the major characteristics of construction, the joint, the components to be joined, and the degree of generality aimed at in the solution. These matters are discussed in detail in the text. The order in which they are taken is not absolute. A relationship probably nearer to the true design process is shown in the list of contents but actual priorities are dictated by the job in hand. The approach adopted has been to deal in turn, although not necessarily in strict order, with principles, examples, and

recommendations (including the prospects for conventions) under each chapter heading. It is hoped that this survey of principles of good joint design will also illustrate that arbitrary standardization is undesirable.

It will be of considerable advantage to designers if information about components and their joints, including jointing products, uses a standard terminology and follows a standard order. A further need will arise for a fully worked out set of details for all the foreseen situations of use, and the trade literature describing components and their joints will need to be factual and informative.

LIST OF CONTENTS

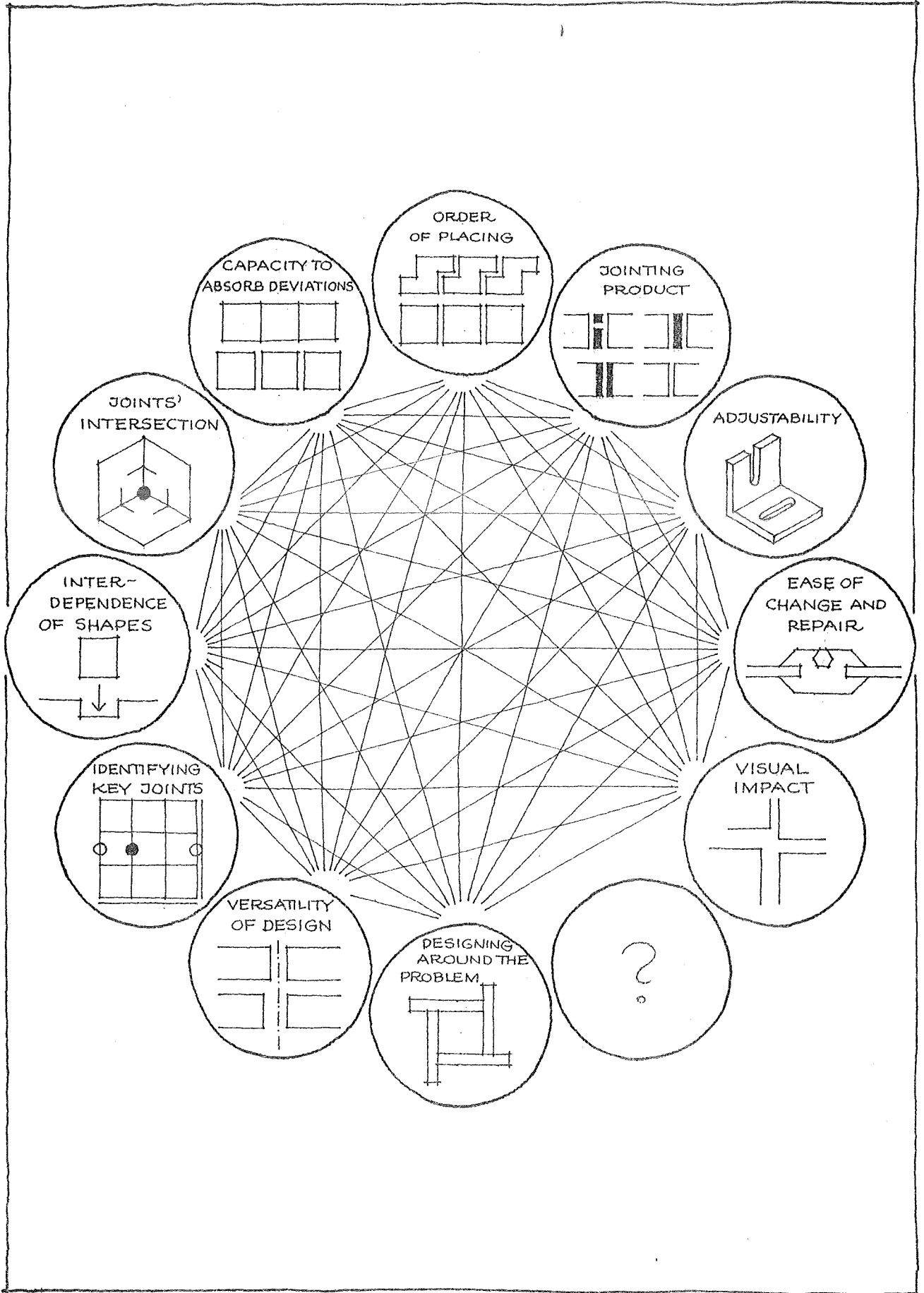

DESIGNING AROUND THE PROBLEM

- Some of the art in good building design is in reducing or eliminating problems before they arise. While the principle is applicable to joint design it should not be taken to extremes. For example an attempt to reduce the frequency of joints in an assembly could well mean an increase in absolute size of components and a consequential increase in inherent deviations due for example to moisture or temperature variations. This in turn increases the demands on the joint and jointing products.
- Fig. 1.1
- One way of avoiding problems known to attend particular joints is to rearrange the components of the design so that they do not occur. Structure to cladding joints may in some cases be made less demanding by running the cladding clear of the structure instead of fitting between, provided the consequences for other joints and other functions are acceptable.
- Fig. 1.2
- The junctions between kitchen cupboards and enclosing walls may be circumvented by choosing lay-outs with at least one end free.
- Fig. 1.3
- It is no use whatsoever in turning to a lapped joint to avoid the problems of fit if by so doing the problem is merely transferred from one plane to another, especially if warping or twist cannot be adequately controlled.
- Fig. 1.4
- The recommendation, therefore, is first to try to ensure that a foreseen problem does not arise by suitable choice of basic layout, second to reduce its severity by techniques such as fitting clear of rather than fitting between, and thirdly try to transfer the problem to a point where it becomes easier to solve.
- Fig. 1.5

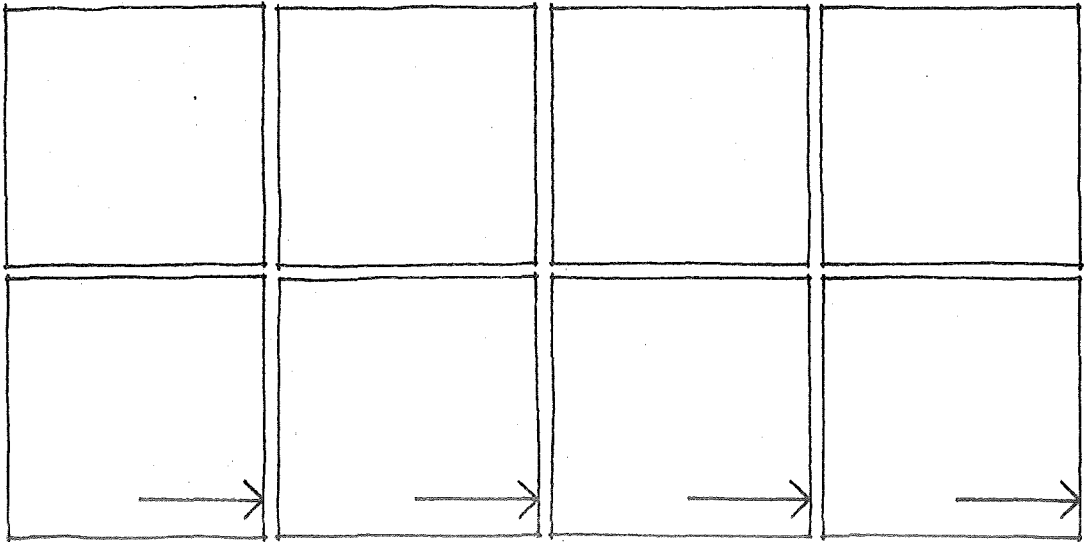

MANY JOINTS - SMALL MOVEMENTS

FEW JOINTS - LARGER MOVEMENTS

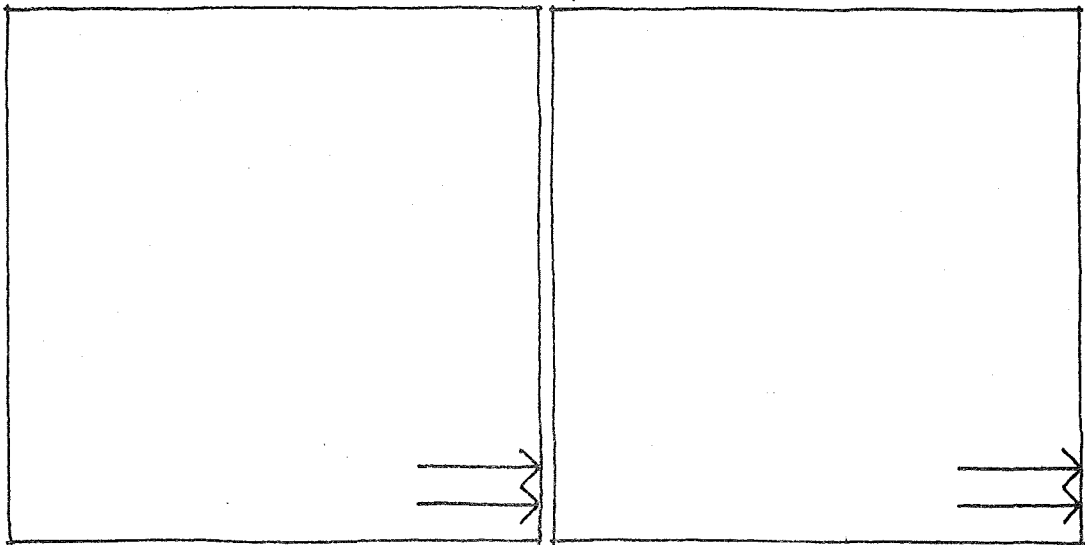

Quite simply to omit a joint does not always solve the problem.

IMG / CIB W24
AD HOC GROUP: JOINTS
E-314 (002) HWH 740125

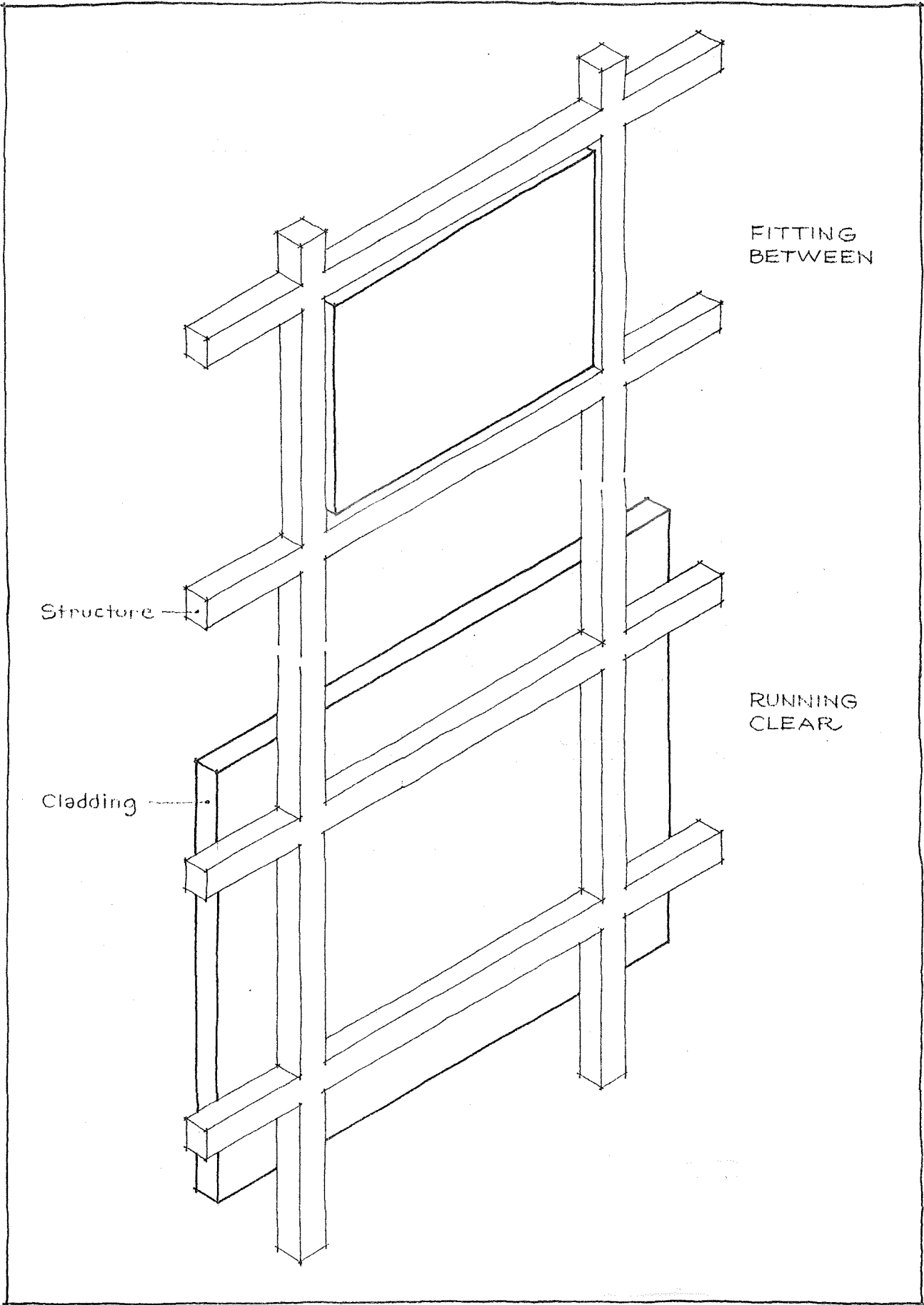

Structure to cladding joints

IMG/CIB W24
AD HOC GROUP: JOINTS
E-314(003)HWH 740126

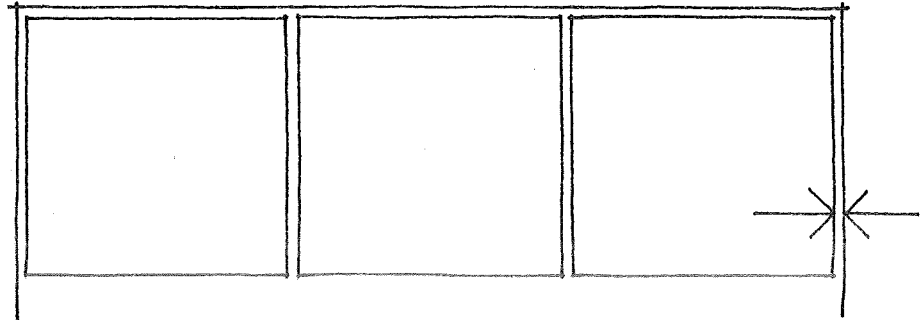

CONTAINED END CONDITIONS

FREE END CONDITIONS

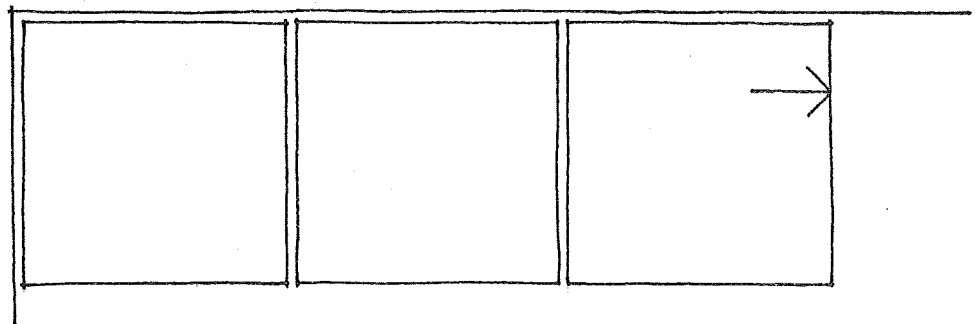

When plan lay-outs are sketched it is often decided at the same time - maybe unconsciously - how difficult jointing will be.
(Example: Kitchens)

IMG/CIB W24
AD HOC GROUP: JOINTS
E-314(004) HWH 740126

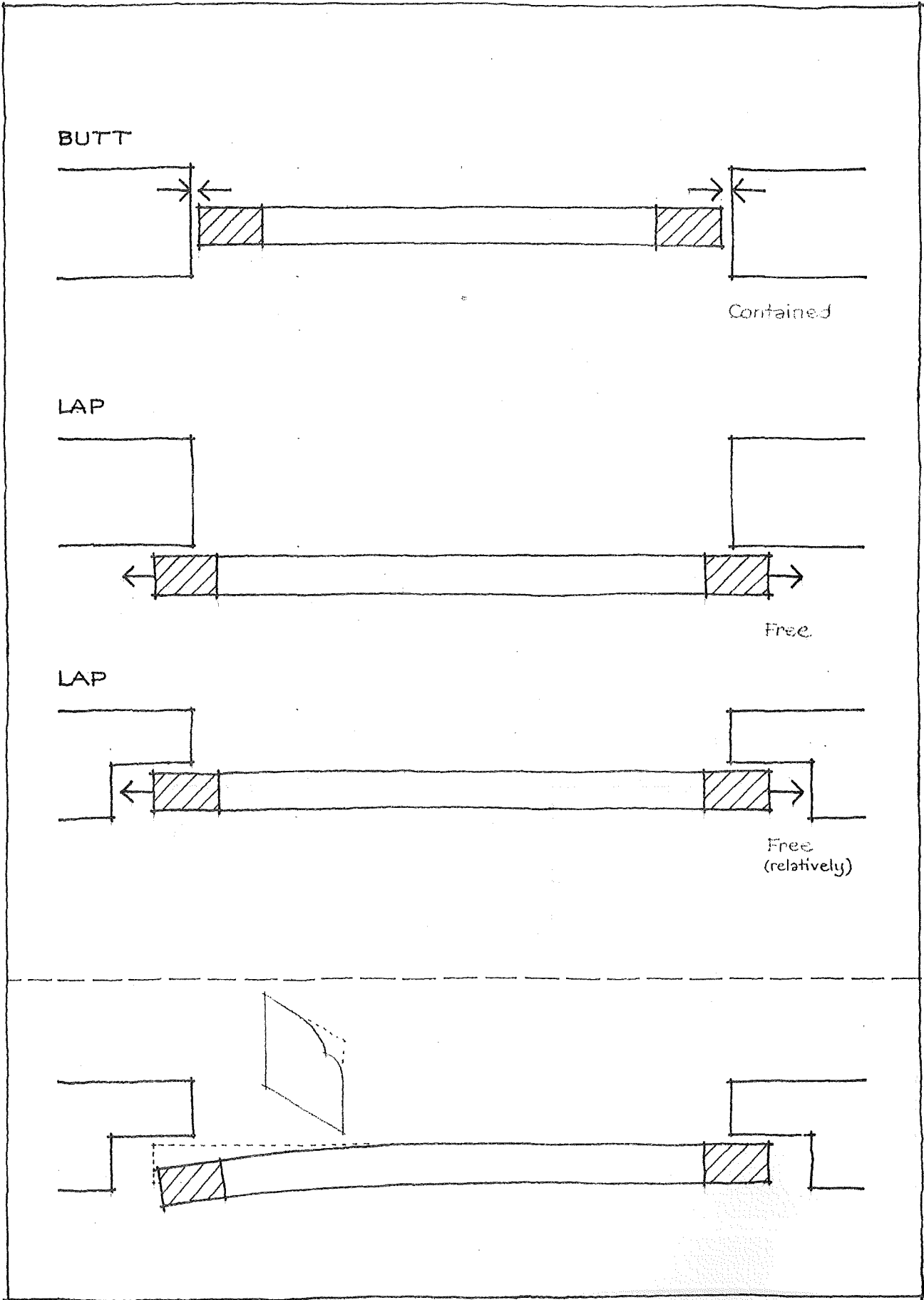

Attempts to obtain easier fits may be frustrated if the component is warped.

IMG/CIB W24
AD HOC GROUP: JOINTS
E-314(005)HWH 740127

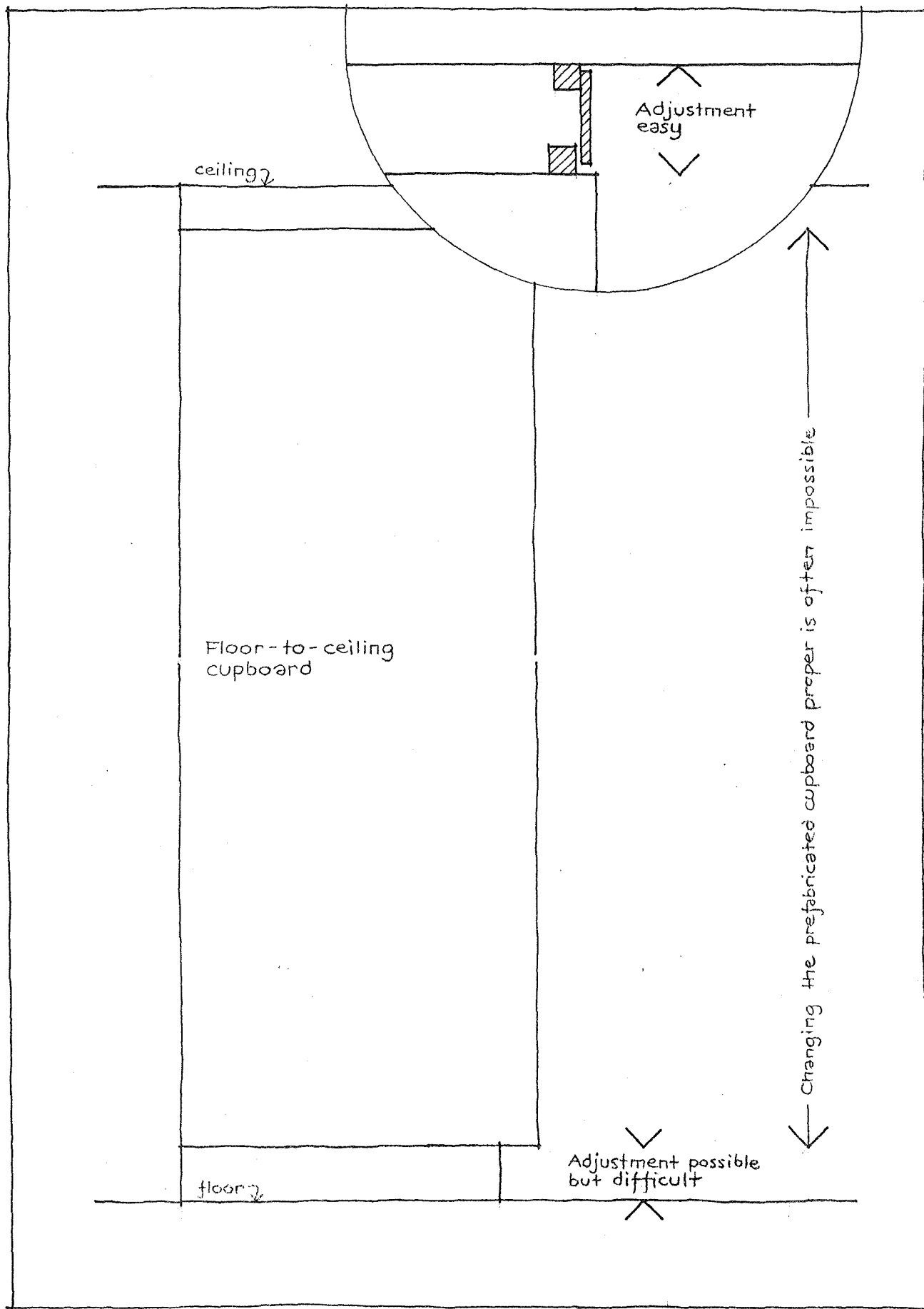

Fitting problems transferred to where they are easy to solve

IMG/CIB W24
AD HOC GROUP: JOINTS
E-314 (006)HWH 740127

VERSATILITY OF DESIGN

The principle usually followed in designing catalogue components and their joints for the open market is that a component designed to be joined to (almost) any other component ie to unlike components has a very wide field of applicability, possibly a favourable market position, and probably a very complex set of joint solutions. However much one may wish to design for unknown conditions this is impossible by definition. It can only be by accident that all conditions are met. The most that can be done is to select profiles etc. which can easily be adapted. Simple shapes are here the key.

In practice, a component is often designed to be joined to particular components, ie to a limited (and defined) number of like and unlike components under foreseen conditions, comprising a foreseen number of joint solutions.

Fig. 2.1

The component designed to be joined to like components or to a very limited number of similar components under well defined conditions has usually a very limited field of applicability, and very simple and/or well-defined joints, although even the preferred joint between two identical standard components often must have alternative solutions for the statistically rare, but economically allowable, extreme size variations.

For a joint to perform as intended, its finished width must lie within certain limits. A lower limit may be dictated for example by least width of material able to accommodate expected movements, while the upper limit may be fixed for example by costs, by lip seal pressure for gaskets, or by depth of grooves for location of a baffle.

Fig. 2.2

It is difficult to give general guidance on the sizes and shapes of joints, since these are often determined from individual criteria for each case. A single dimension such as target joint width may also be misleading since each joint will in practice be usable over a range of widths.

Some authorities have suggested trying to fix categories of joint width (for example: fine, of the order of 2 mm, medium, of the order of 10 mm, and coarse, of the order of 25 mm) but there is little evidence to justify this approach. If these dimensions are used as deductions from co-ordinating size, then notional consistency is achieved only between components having the same deduction. In the case of unlike components from different groups the joint margins will not correspond, and consequently neither will the theoretical, let alone the actual total clearance fit into any predetermined category.

Before attempts are made to establish conventions for particular groups of components an examination should be made of prospects for making these parts of a much more generally applicable discipline.

Nevertheless in relation to sizes certain minima and maxima may - and should - be identified. For example a minimum allowance is needed to allow a component to be manoeuvred into place, to allow clearance for insertion of jointing products, and to allow for compression to take place without displacement, while maxima may be determined by cost, say, or slump.

Careful consideration of the effects of induced deviations, that is to say the cumulative effects of marking setting out lines,

positioning of components, and manufacture of components is likely to be well repaid. Experience shows that the deviations in the first two categories can have greater significance than those in the third. The extent to which any one of these affects the dimensions of the joint depends on the nature of the assembly concerned. If for example the components may be moved during or after installation either because it is natural to do so or for contractual reasons, then the effects of their own positional deviations for all practical purposes may be eliminated. If the components are required to fit within a space of which the deviations are known, then the minimum allowance can be obtained by recognised statistical techniques. This allowance should then be adjusted to accommodate inherent deviations, that is to say for example those deviations due to moisture and thermal movement of the components, and the dimensional needs of the joint.

The designer may change the values of any variable in this relationship. He may for example decide to assume values for deviations other than those likely to exist and accept a correspondingly differing proportion of misfits, or he may require deviations to be kept within tighter limits where practicable, so as to use particular jointing techniques. Among the other options available would be deliberately to restrict the field of applicability to those few conditions for which an easy solution may be found, or to develop special joints for the small proportion of cases which will be outside the capacity of the chosen joint range. In the last case there would need to be a method of predicting the distribution of joint sizes.

Fig. 2.3

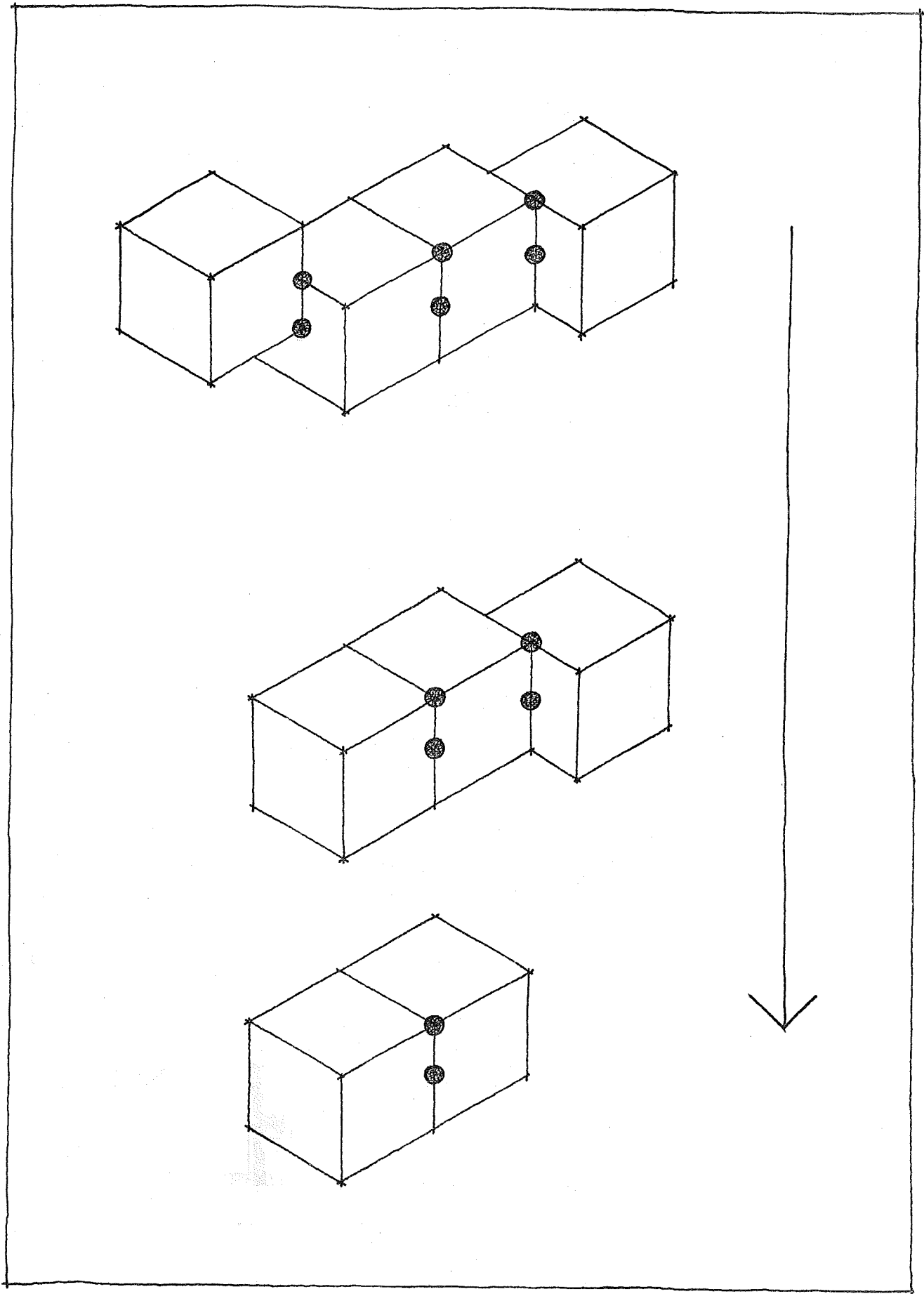

Restricting field of applicability may facilitate joint design

IMG/CIB W 24
AD HOC GROUP: JOINTS
E-314(008)KB 740127

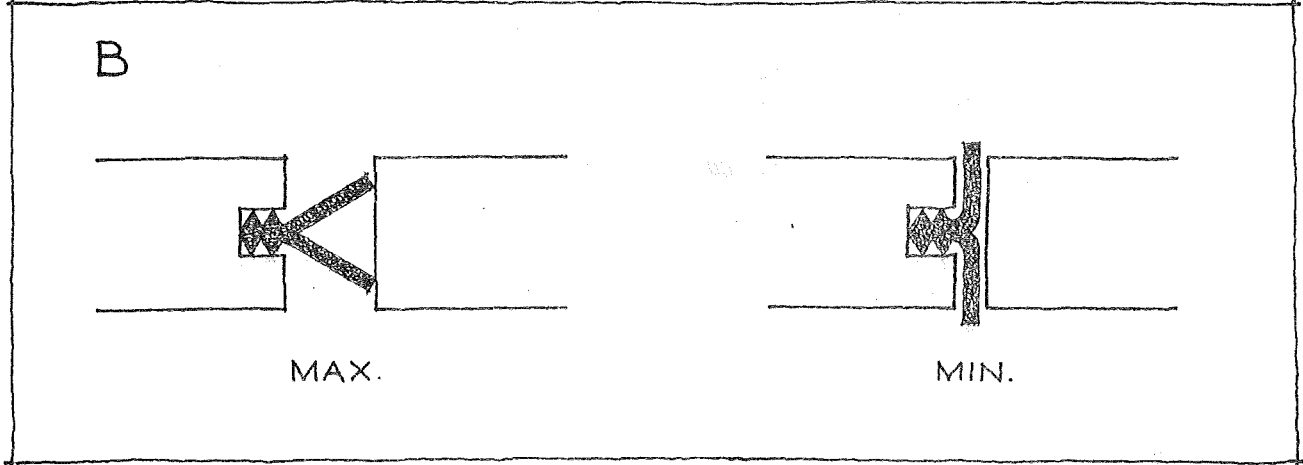
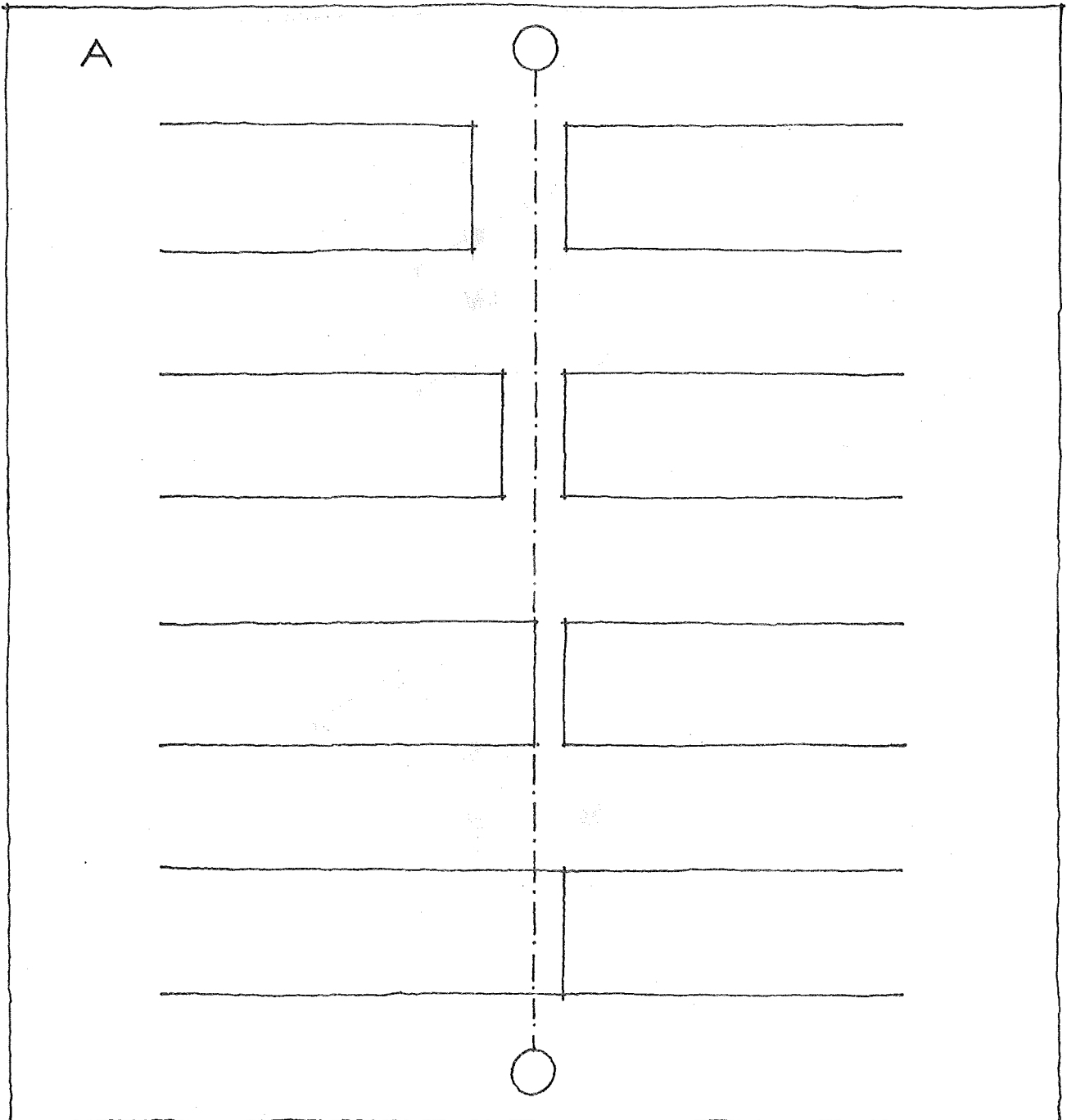

Component application will indicate type of joint design (A)
Finished width of a specific joint design must lie within certain limits (B)

IMG/CIB W24
AD HOC GROUP: JOINTS
E-314(007)KB 740127

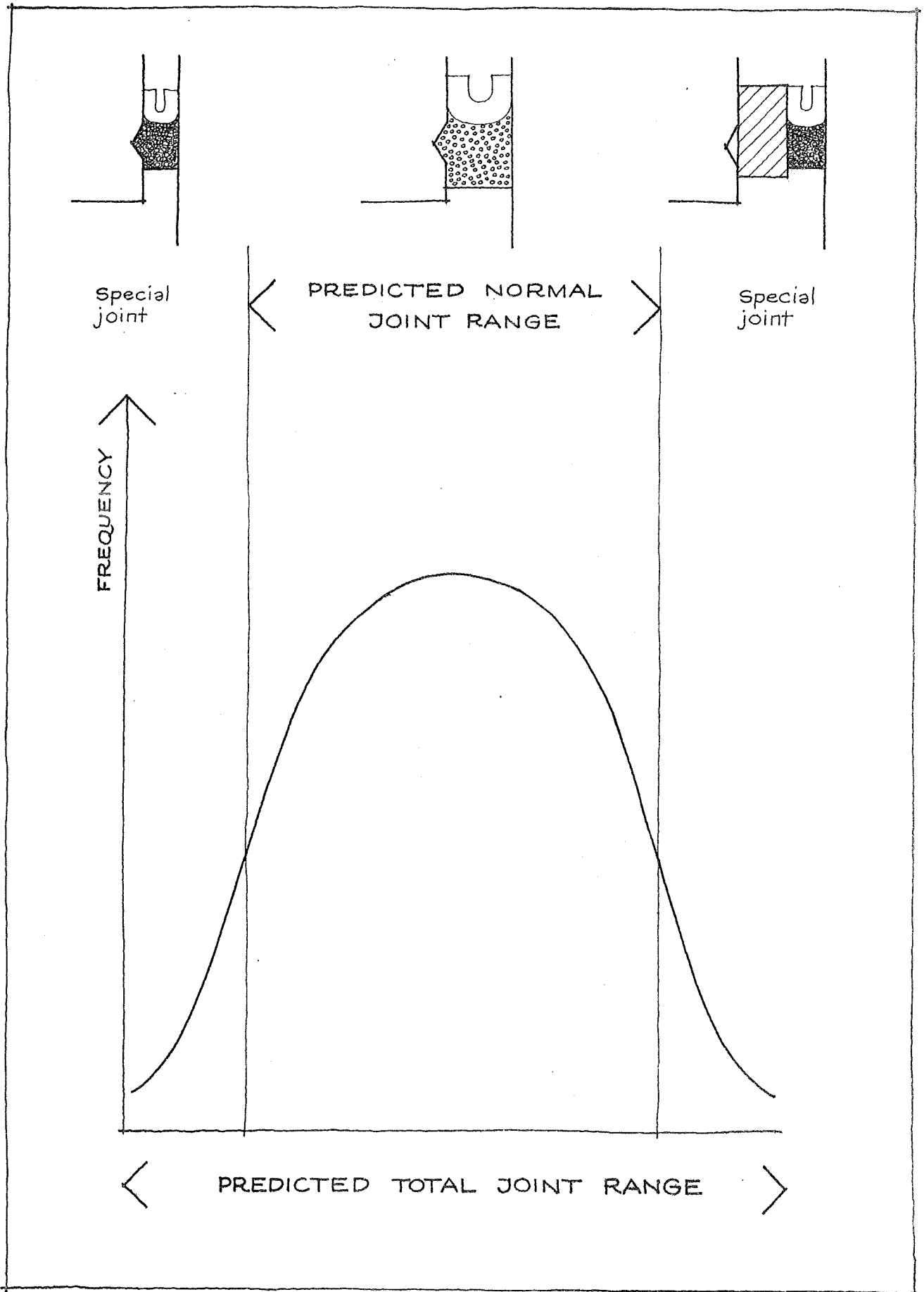

IDENTIFYING KEY JOINTS

Any building comprises a large number of components and of joints and, therefore, also an extensive labyrinth of joint design problems. Each component may in itself give rise to a number of joint problems, as the component may be used under several conditions, as the edges of the component may be different, and as an economic and technical relationship usually exists between many components and their corresponding joints. The optimisation process is very complex, whether seen from a client's or from a manufacturer's viewpoint. Usually the initial approach is to find the key joint(s), possibly the most widely used (repetitive?) joint, the most costly joint(s), or the most difficult joint. What is the field of applicability of the component; ought the corresponding joint to cover the entire field; are alternative joint solutions feasible etc.?

The identification of the key joint may be the king-pin in the entire design process, or in the cost-benefit analysis of the marketing of a component. Although the establishment of principles is not easy, some will be self-evident from the following examples.

Fig. 3.1 A

Fig. 3.1 B

First of all the key joint may not be the "normal" repetitive joint between two like components. If only a few components are joined, the border joints may be the key joints. Another example is a precast gable of a four-storey block, where the components are:

Component	Conditions	Number
A	Normal (?)	4
B	Border joint, right corner (facade type x or type y)	2
C	Border joint, left corner (facade type x)	2
D	Border joint, basement	2
E	Border joint, roof	2
F	Two border joints, right corner, basement	1
G	Two border joints, left corner, basement	1
H	Two border joints, right corner, roof	1
I	Two border joints, left corner, roof	1

B may be, or may not be, a handed version of C. The same applies to F/G and to H/I. D, F, and G may not have a border joint against the basement, as the basement may be designed to allow for the "normal" bottom edge of D, F, and G. Similarly, the roof may be designed so that E, H, and I can have "normal" edges against the roof.

The gable has 16 gable components of which - in the worst case - only four are "normal" components with repetitive joints. The other components may have one or two special edges against facades, roofs, or basements. In the worst case, we have but 12 repetitive horizontal and 12 repetitive vertical joints out of 40 joints.

The optimal solution to the design of the components, of possible extra "corner components", of the joints, and of the adjoining facades, roofs, and basements etc., may start with a key joint (which one?), later taking other factors into account. The above examples draw attention to the border conditions.

The aim is to use
 as many standard components as possible,
 as many standard joints as possible,
 and at least one must give way when unlike components are joined
 - unless the case has been foreseen and solved by a versatile
 joint or a special jointing component or product.

Fig. 3.2

In case of room sized sandwich-panels it may be possible to design the edges of the panels alike in joints A, B, and C. If so, all three components are identical. Joint A must be watertight, wind-tight etc. and must accommodate (possibly cover) the edge of the floor. Joint B has the extra problems of a probably cast-in-situ basement. Joint C has to take the roof components etc. into account. An extra roof-edge-component may facilitate the transition of the materials and functions of a roof to the materials and functions of the facade component. The upper edge of the upper facade component may be normal, but quite often has a special upstand offering the cheapest solution to the roof-edge problem.

Fig. 3.3

The closely linked problems of components and joints, and their relative positions are also illustrated by two possible plans of a staggered and stepped building.

Plan A has several disadvantages: The re-entrant gable/facade corner is more complicated than in plan B, where the building is made from standard facades between standard crosswalls at regular intervals. The wall components must be designed to support alternate floors, increasing the number of components and joints and/or complicating the design of components and joints. The design of components and joints in adjoining floors, gables, facades etc. is made more complex in plan A than in plan B.

Plan B has much more simple, "normal" components and joints, and a statically sounder structure. The advantages can easily counteract the (theoretical) extra cost of components/materials, when compared with plan A.

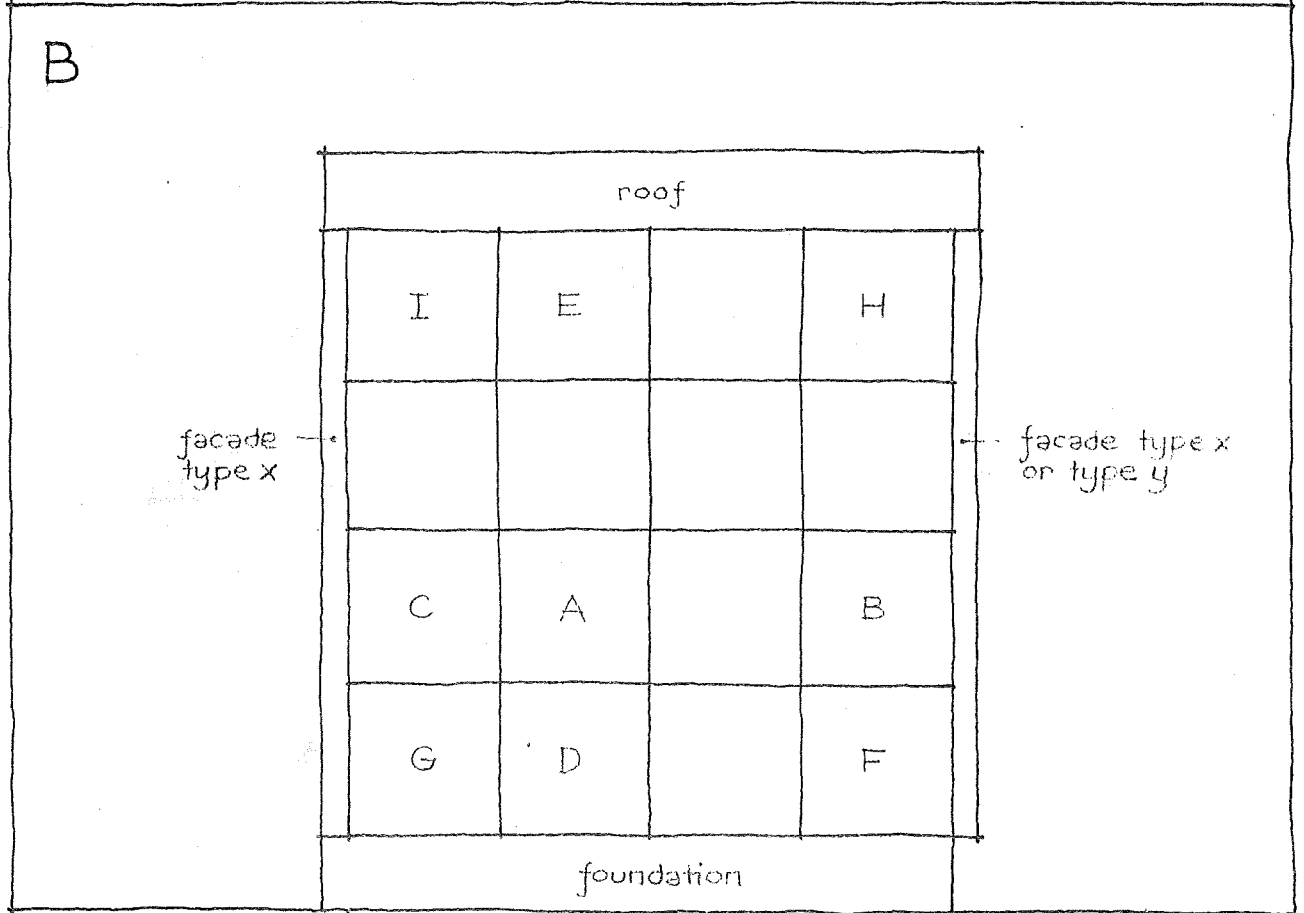
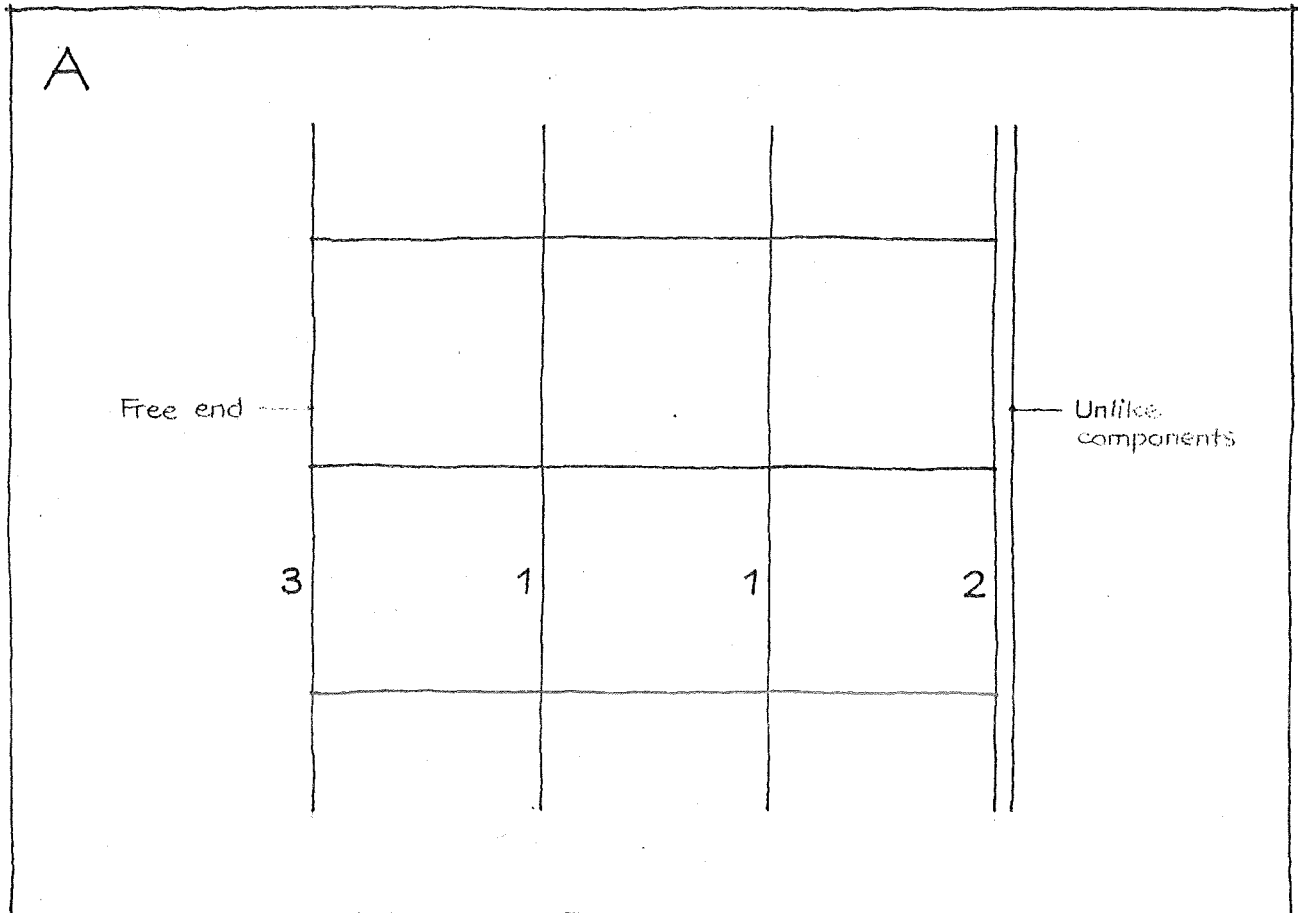

A: The repetitive joint (1) is not necessarily the key joint.
 B: Example; a gable which may only have four "normal" components

IMG/CIB W24
 AD HOC GROUP: JOINTS
 E-314 (010) JMP 740212

Example:
Facade panels on three-storey building.

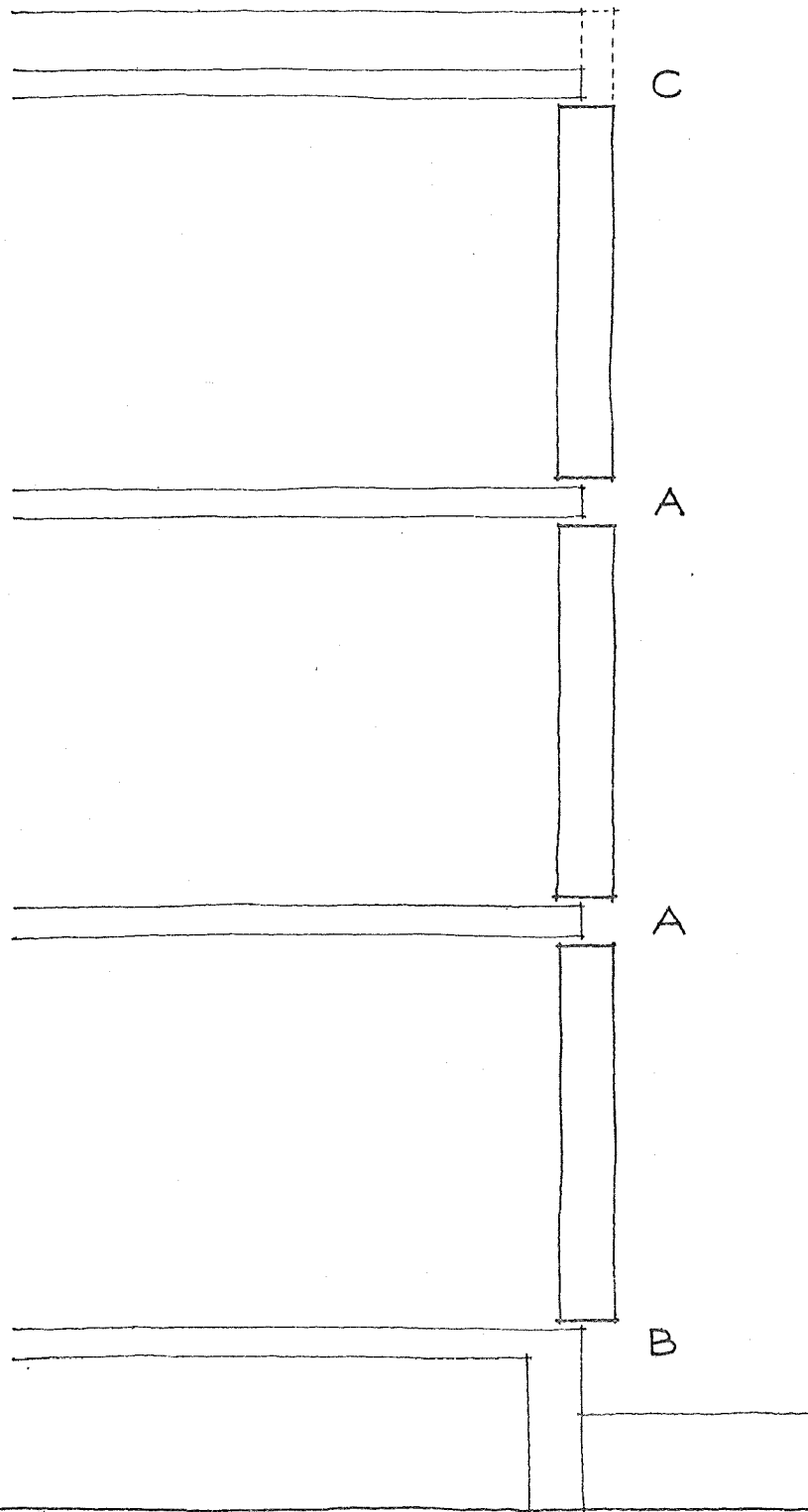

The three facade panels may be identical if the joints at A, B and C are considered simultaneously.

IMG/CIB W24
AD HOC GROUP: JOINTS
E-314(011)JMP 7402.12

Example

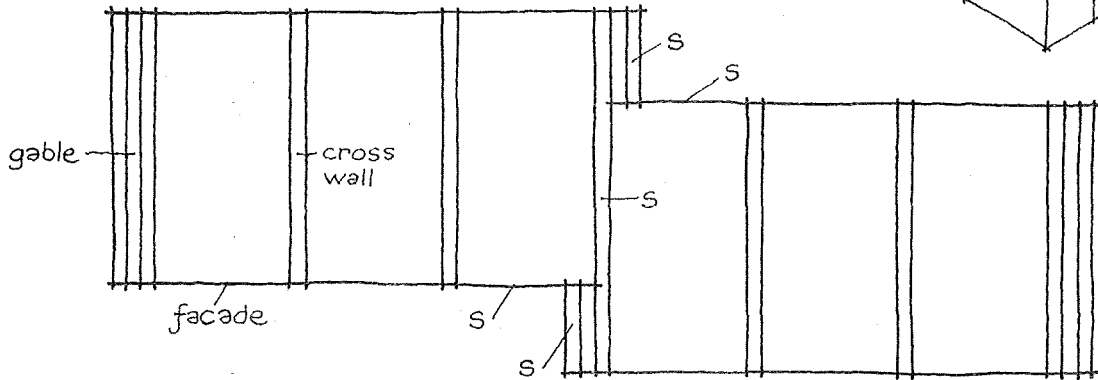
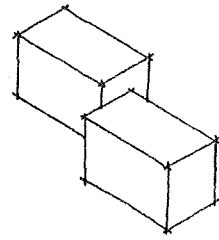

Plan A

S = special

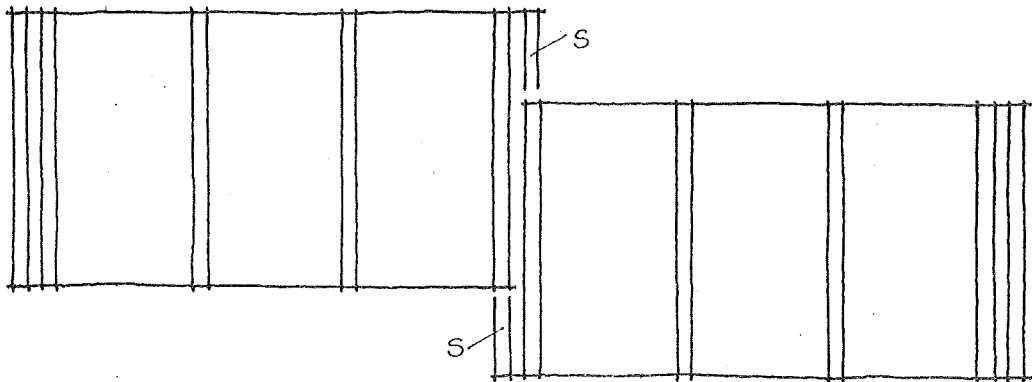

Plan B

Plan of stepped and staggered building.
 The Plan B version will normally mean less complicated
 components and joints.
 Key joints may be found at the party wall.

IMG/CIB W24 AD HOC GROUP: JOINTS E-314 (012) JMP 740213

INTERDEPENDENCE OF SHAPES

Every link in a job process contains sources of inaccuracy which may contribute to deviations. These deviations may in turn influence later job processes. Even where each single deviation is kept small, accumulation can produce considerable resulting deviations.

Tighter demands for accuracy will normally imply increased expenditures at manufacturing, assembly etc. Large demands should therefore not be put on accuracy where it is not necessary (thus accuracy which is not used for anything, is not necessary). The milder the demands as to accuracy and the fewer the requirements that must be fulfilled simultaneously, the easier it will be to fulfil them.

The above considerations are important in connection with the design of joints because they lead to the general rule that unnecessary interdependence of shapes should be avoided.

When assembly of components occurs with contact joints (close-butted joints) there will generally be a greater degree of interdependence between the components' shapes than when assembly occurs with a reasonable space left for the joint.

Fig. 4.1

When contact is desired, the interdependence will show itself in that the components must be made with accuracy. But when a certain space is left for the joint between components it is often possible to correct for inaccuracies (for example, those derived from manufacturing and assembly).

Contact assemblies with components of many organic materials or components which at manufacturing must undergo a firing process should be avoided, as such components can only with difficulty satisfy demands of great accuracy. As an example most components of fired clay are normally assembled with a variable mortar joint, both in the case of brick-to-brick assembly and in the case of assembly with other types of components. Assembly of wooden components (joinery) with components of other kinds of material is also usually accomplished with a variable joint. Assembly between joinery components, on the other hand, can often be made with contact joints. Assembly of metal components can normally be based on contact joints without making larger demands on accuracy than is normal for this kind of work.

When components are assembled surface-to-surface there will usually, even with normal joints, be a strict interdependence between the components' shapes.

In the case of surface-to-surface assembly, inaccuracies must be avoided not only for dimensions and angles but also in the shape of "Waves", distortion etc. It will therefore be necessary to put comparatively strict, or even possibly unobtainable, requirements on accuracy in connection with surface-to-surface assembly. All other assembly conditions such as surface-to-edge, edge-to-edge etc. will normally imply a less strict interdependence of shapes.

If, in the assembly of components, there are several sets of conditions affecting shape that demand to be fulfilled at the same time, then the interdependence between shapes will be especially large.

As an example, inaccuracies with a component that will be assembled with another component only at one surface or edge, can often be counteracted by adjusting the position of the component (i.e. kitchen table-top against a wall). If the same component is to be

assembled with other components at several surfaces or edges simultaneously, inaccuracies in the component can make it necessary that shapes etc. must be changed before assembly can take place (i.e. kitchen table-top in a recess in a wall).

To avoid unnecessary interdependence of shapes is not an unknown problem for designers and craftsmen. In conventional building a series of rules has been routine for many years:

1) (Contact or space) With all types of components that cannot be produced with great accuracy, assembly is based on a joint of suitable size (comparatively broad and often variable joints). Where it has been necessary to sidestep the above principle, the jobs in question became special work (such as wooden staircase and similar carpenter's work) which required a high degree of craftsmanship.

2) (Surface, edge, or point) Where it is possible, surface-to-surface assembly is avoided and replaced with surface-to-edge assembly, edge-to-edge assembly, etc.

As an example, skirting boards and door mouldings are often hollowed out on the back, which makes the assembly with the wall edge-to-surface instead of the more demanding surface-to-surface.

3) (Simultaneousness) Where it is possible, assembly of components at several surfaces or edges at the same time is avoided. Each single component is thus designed to have the largest possible number of surfaces and edges free.

Where simultaneous assembly between several surfaces and edges is necessary, the undesired interdependence of shapes which then occurs is often counteracted by the use of special joints between the components so that their position can be adjusted. In this way expansion, shrinkage, setting, and casting can be accommodated without inconveniences (as an example, panels in cabinet-work, joist-ends in gaps in masonry walls).

Newer building methods follow very much the same rules. Thus can be mentioned the mounting of wall components of concrete on to mounting bolts with nuts, whereby surface-to-surface assembly is avoided. However, in these new building forms it is not possible to rely upon accumulated traditional knowledge. The necessary knowledge about how to achieve independence of shapes must be available when the components are being designed.

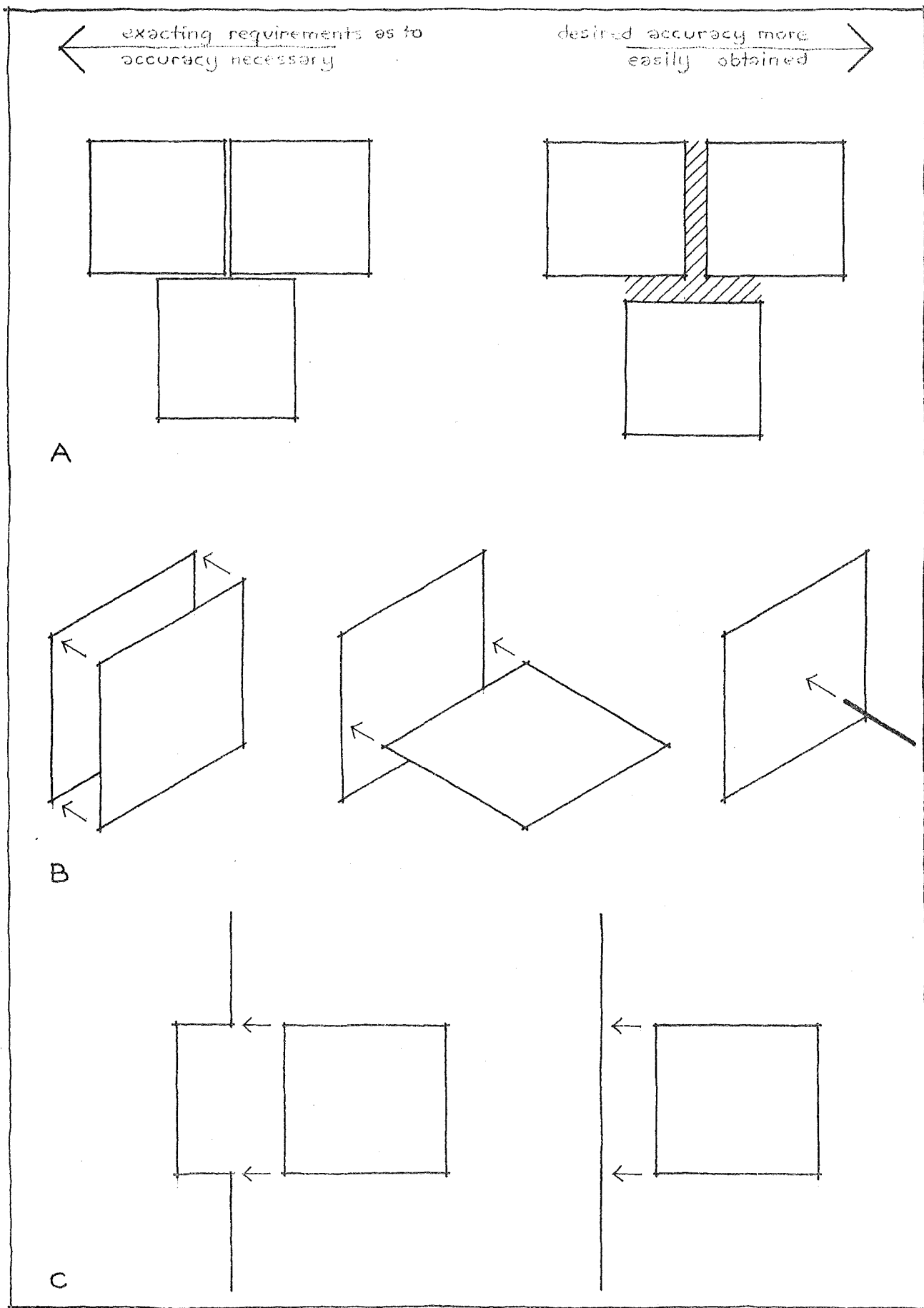

A: Contact joint → wider joint
 B: Surface to surface → edge to surface → point to surface
 C: Interdependence of many factors simultaneously → interdependence of fewer factors.

IMG/CIB W74
 AD HOC GROUP: JOINTS
 E-314(013)K6. 740213

JOINTS' INTERSECTION

A decision must be taken on what conditions are to be provided for in the design: it should be remembered that joints will follow building surfaces; they cross, bend, and sometimes end, and all these conditions should be examined during the process.

It is common experience that designers will produce elegant solutions for the horizontal joint and for the vertical joint, and conveniently forget about the intersection. This is where many problems occur.

Fig. 5.1

The possibilities cover a wide range, from end to end joints in a single plane, through two way joints, three way joints in one or two planes, and four or more joints in three planes. This can best be illustrated by some examples:

One example which occurs frequently is the discontinuity in air seals brought about when they are not in the same plane, or when baffles inserted into a vertical joint need flashings where they cross a horizontal joint.

Another problem which does arise in open drained joints is the inadvertent continuity of cavities round corners of buildings. Since air pressures on the different surfaces will vary, this may give rise to a problem unless a cavity stop is introduced; the stop may also be needed for fire prevention purposes.

While it may in theory be desirable to keep joints away from corners, this can have very limiting effects on interchangeability.

Fig. 5.2

A satisfactory solution is rarely designed in the case of cover moulds forming the joints between a kitchen cupboard fitting into the corner of a room and the vertical surfaces adjacent to it.

Fig. 5.3

In the case of weather check grooves on wood windows, it sometimes happens that because of continuous sections, the groove or a joint is inadvertently carried down into the cill on the side of a tenon or jointing finger, with a consequence that water will find its way through the cill.

The recommendation is, other things being equal, to arrange for as few joints as possible to meet at any point. Thus a three-way intersection may be easier to solve technically than a four-way, albeit with other implications, eg at some consequence in assembly technique.

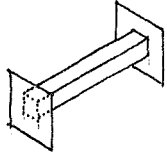
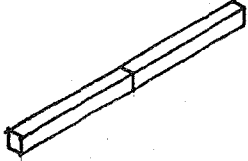
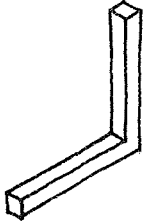
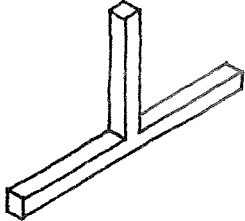
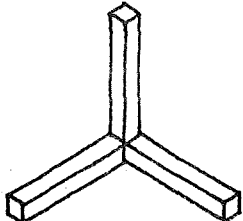
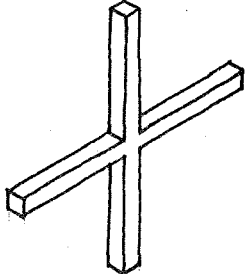
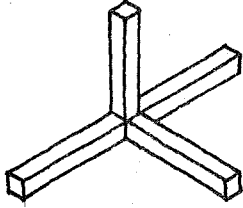
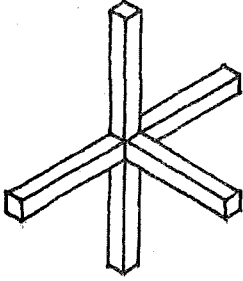
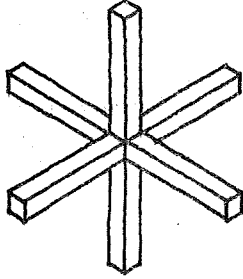
 <p>[Joints end]</p>		
		
		
		
		
		

For any joint design: At how many types of intersections should it be applicable?



IMG/CIB W24
 AD HOC GROUP: JOINTS
 E-314 (014) KB. 740128

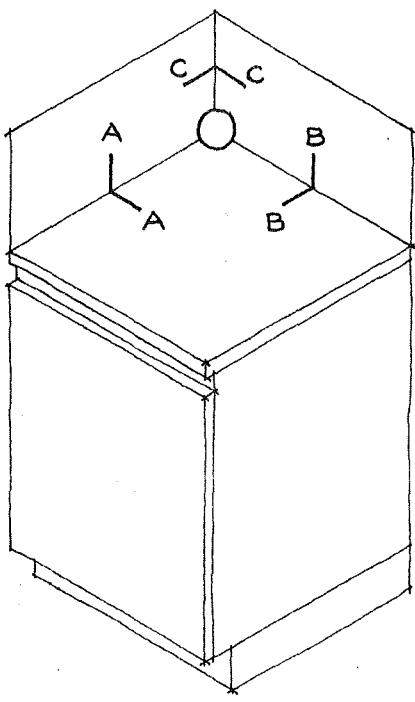

Example:

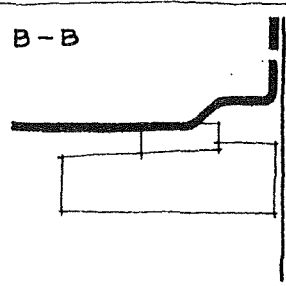
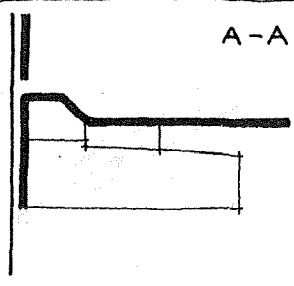
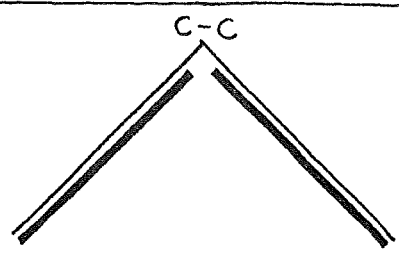

↓
Joints'
intersection
?

The joints A, B and C are too often not especially well designed - and their intersection not studied at all!

IMG/CIB W24
AD HOC GROUP: JOINTS.
E-214(015) KB 740201

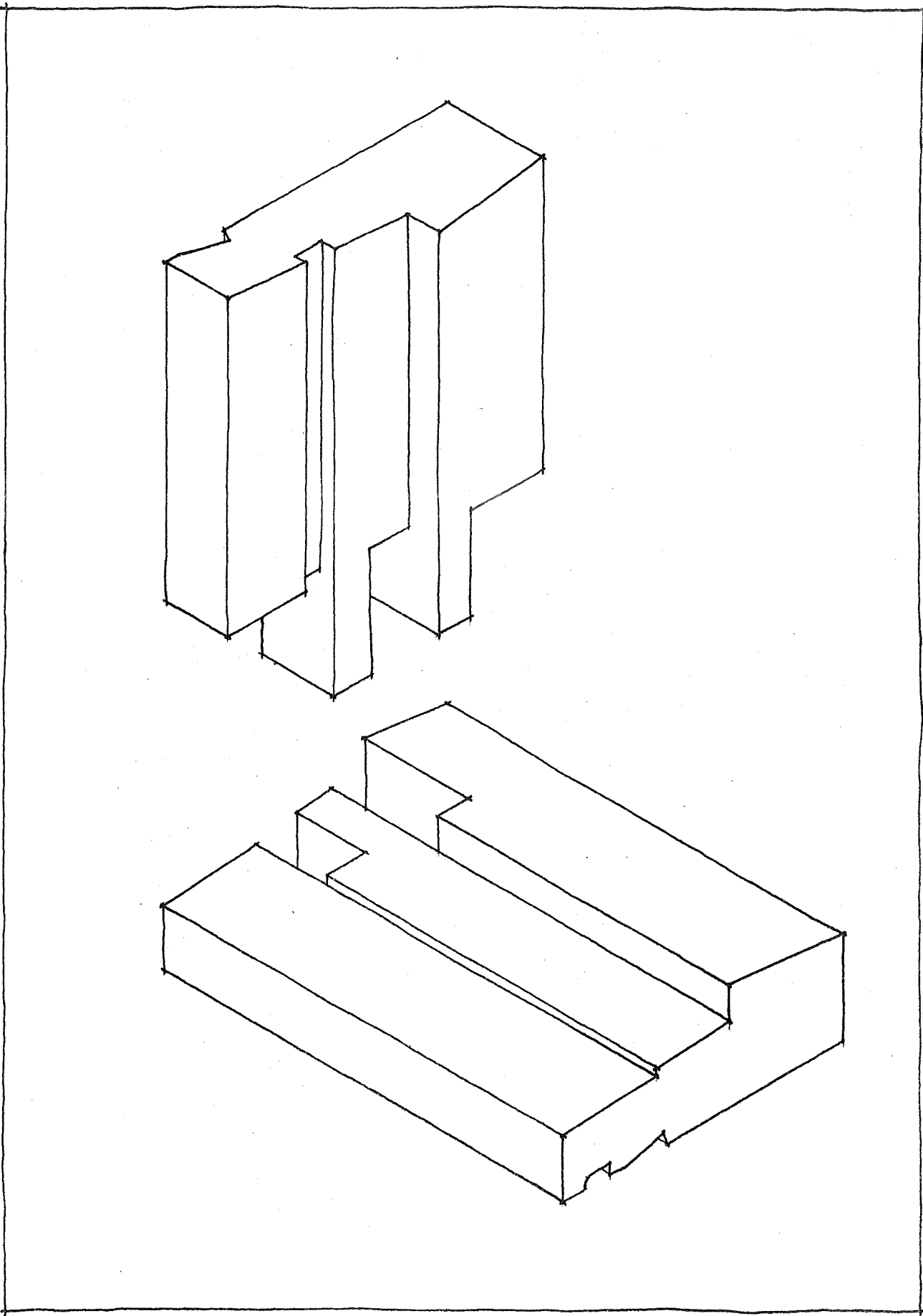

Any unpremeditated change of either profiles, tensions or weather groove would wreak havoc to this design!

IMG/CIB W24
AD HCC GROUP: JOINTS
E-314(016)HWH 740129

CAPACITY TO ABSORB DEVIATIONS

Deviation is the designation for any type of difference between a specified and an obtained size or position. Deviations which occur because of the nature of the materials from which the components are made or as a result of changes in temperature and moisture content, are known as inherent deviations. Man-made, or induced, deviations, on the other hand, result either from craft or machine processes, or from assembly on site.

In planning and design, it will be natural to work with the specified size. Deviations, as they arise in the later sequence of the building process, can only be coped with if the work is based on a knowledge of tolerances, which limit the allowable deviations from the specified size.

Deviations that are unavoidable occur in the marking out and control of sizes, and are further contributed to by shrinkage, expansion, warping, bending, compression, and settling. Deviations may occur during manufacturing, handling, and installation, and also during storing and later in the finished building.

In the manufacturing of prefabricated components, deviations can be attributed to:

1. Inaccuracy in marking out and control of sizes.
2. The specific properties of the materials employed.
3. The work methods employed.

In connection with point 3 it should be pointed out that this condition most often will be outside the scope of design judgement, and, therefore, usually, it will be the responsibility of the factory to provide the necessary information.

It is of substantial interest to know the deviations at the time of installation, if possible supplemented with information on how the component can be presumed to shrink, warp, etc. in the building.

In assembly of prefabricated components deviations can be attributed to:

1. Inaccuracies in marking out and control of positioning.
2. The characteristics of the components employed.
3. The work methods employed.
4. Size changes in the (partly or completely) finished construction.

The situation is often complicated by the fact that the components being installed are already encumbered, from the manufacturing process, with deviations for which only the limits are known, but not the actual values.

As a rule, the positioning of components will also be influenced by the actual (= inaccurate) position of other components already installed.

A closer appreciation of the problem of deviations must, therefore, require that all links in the building process be investigated closely; this should be tempered by experience, as a basis for which there is no substitute for a carefully recorded set of actual measurements.

The problem of absorbing deviations applies usually to a series of components and joints, not to individual components or joints. The consecutive adding of tolerances for large rows of consecutive, adjoining components, will produce considerable differences between the resulting smallest size with respect to the largest permissible size. But in practice, it will seldom occur that two or more maximum deviations will appear at the same time. Assuming that possible extreme resulting deviations can be accommodated by reasonable measures (extra handling of some components, use of special materials in some of the joints etc.), the sum of the directly added tolerances can be reduced.

How large a reduction factor that can be used in a given case cannot be determined from calculations or by statistical methods alone, but must also be based on an evaluation of the actual conditions, and upon experience which includes the consequences of exceeding the tolerance limits.

In practice the problem is solved by a complicated series of consecutive operations, setting out, erection, adjustment, cutting, with different techniques for different components, in a pattern of overlapping, individual operations.

All these approaches are based upon the following principles:

Fig. 6.1

Taking each dimension in turn, one principle is that the manufacturing and erection deviations on each component are taken up within each component's allocated space, i.e. in the two surrounding joints.

A second principle is that the manufacturing and erection deviations on each component may be taken up to some extent within each component's surrounding joints, but the excess deviations above the capacity of the joints, must be taken care of by other means.

A third principle is that none of the manufacturing or erection deviations on a component can be taken up in the surrounding joints. All such deviations must therefore be taken care of by other means.

The two following examples illustrate how application of the third principle makes necessary careful consideration at the design stage:

Fig. 6.2

- a. A row of close-butted kitchen cabinets of which each has a worksize smaller than the modular size. Even when positive deviations add up, the total of all four components is smaller than the allocated space. A cover-strip, cut to size (or with an overlap) can take up the resulting deviation.

In practice such a cover-strip must be able to take up approx. 30-40 mm as the difference between the smallest and the biggest size.

- b. A row of light weight concrete partition components are glued together (close-butted joints), and have sizes slightly bigger than theoretically necessary (or the last one is deliberately too big). The resulting deviation is dealt with by cutting the last component to size.

In the following example is illustrated how components sometimes are designed with joints according to principle one - but at erection application of principle two is advantageous for practical reasons:

Fig. 6.3

A row of floor components, side by side across a building. The two floor components along the facades have a critical position. The joints should be rather narrow so as to become selfshuttering. Both requirements are fulfilled, except for one joint, absorbing all excess deviations. This particular joint is naturally placed where the resulting consequences, visually and technically, can be taken up.

It is not possible to draw any conclusion about the best principle for absorbing deviations, apart from the simple conclusions that deviations always exist, and that unnecessarily close tolerances cost money.

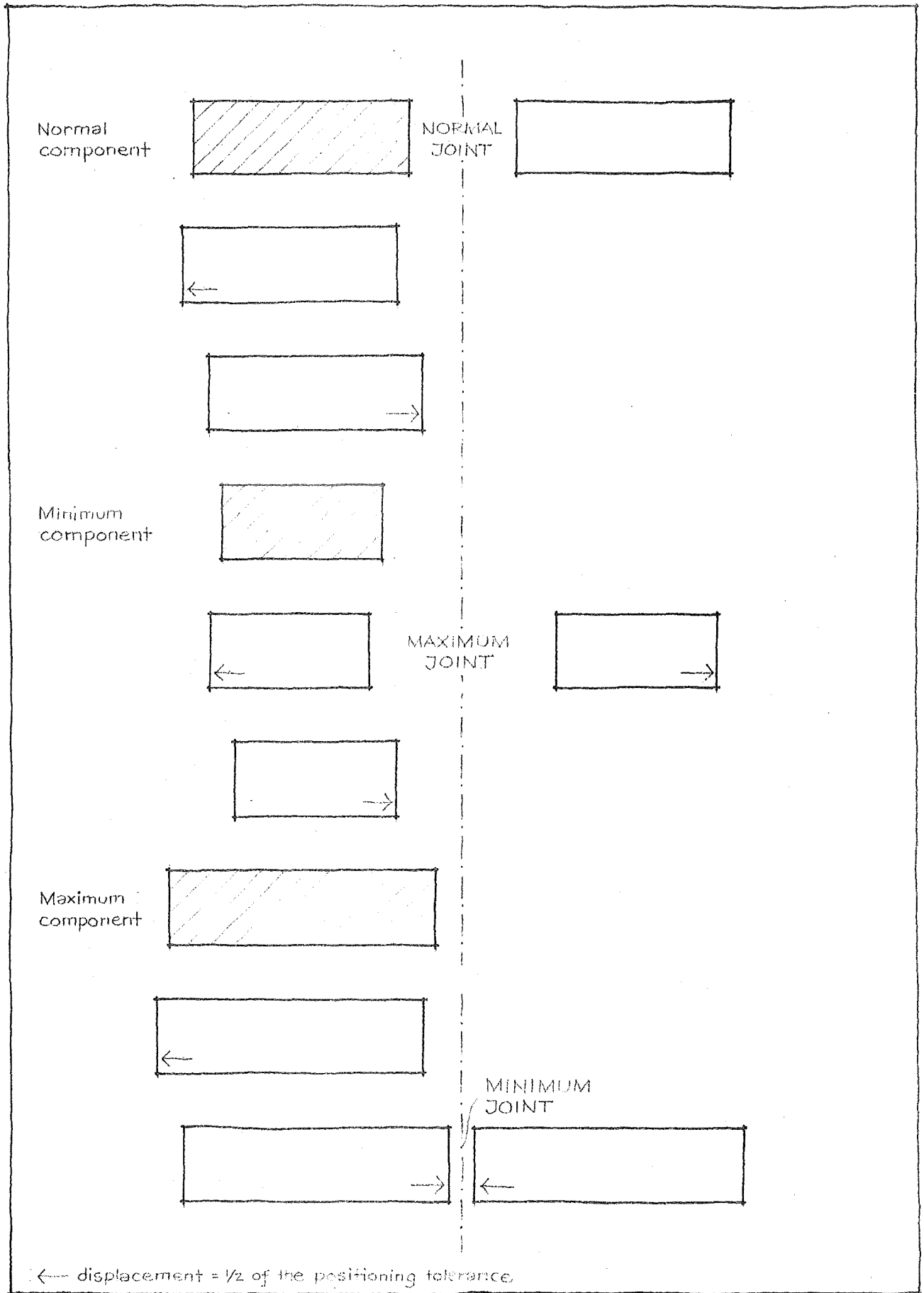

First principle: All deviations stemming from manufacture and positioning of a component are taken up in the surrounding joints.

IMG/CIB W24
 AD HOC GROUP: JOINTS
 E-314(017) KB 740302

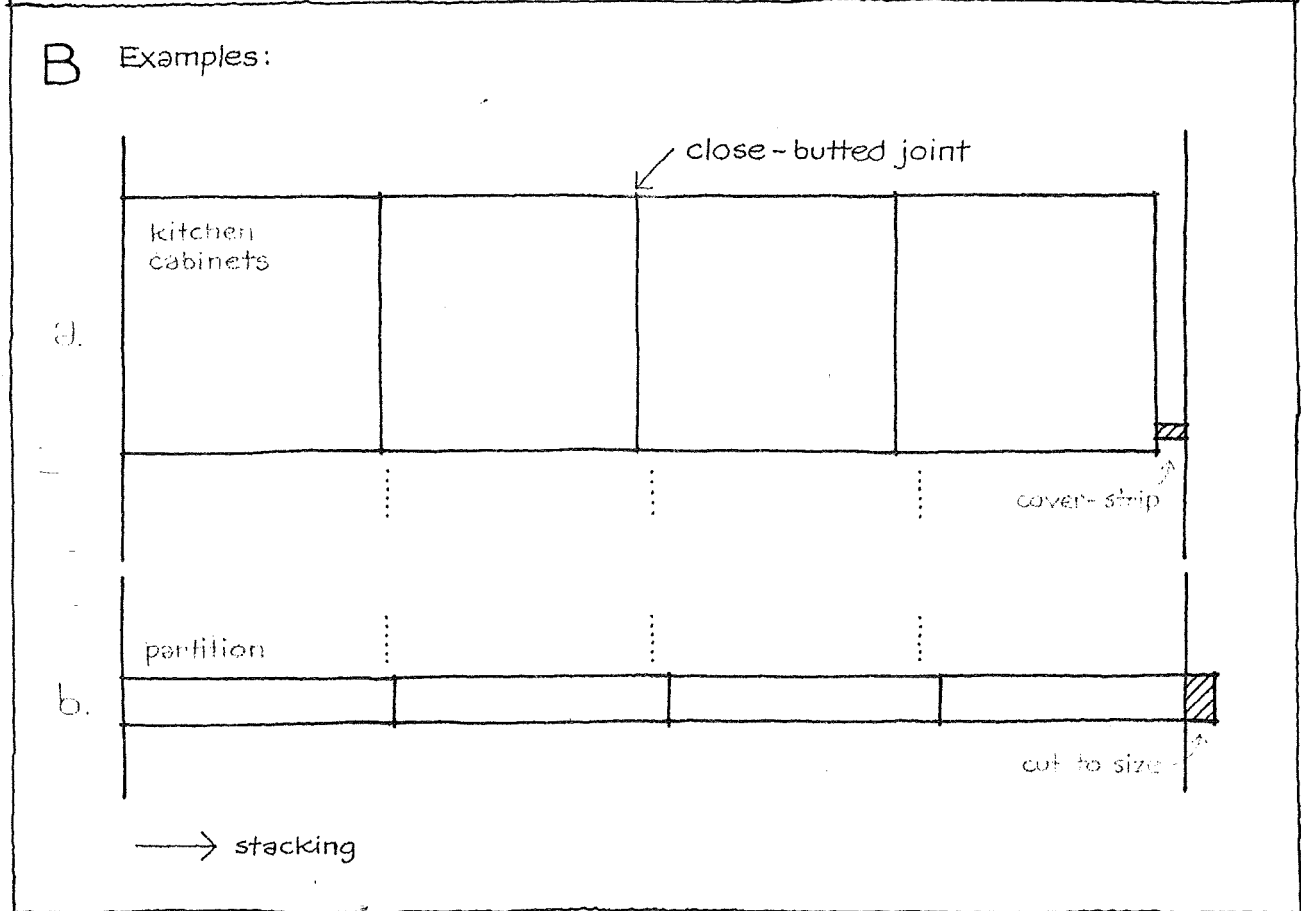
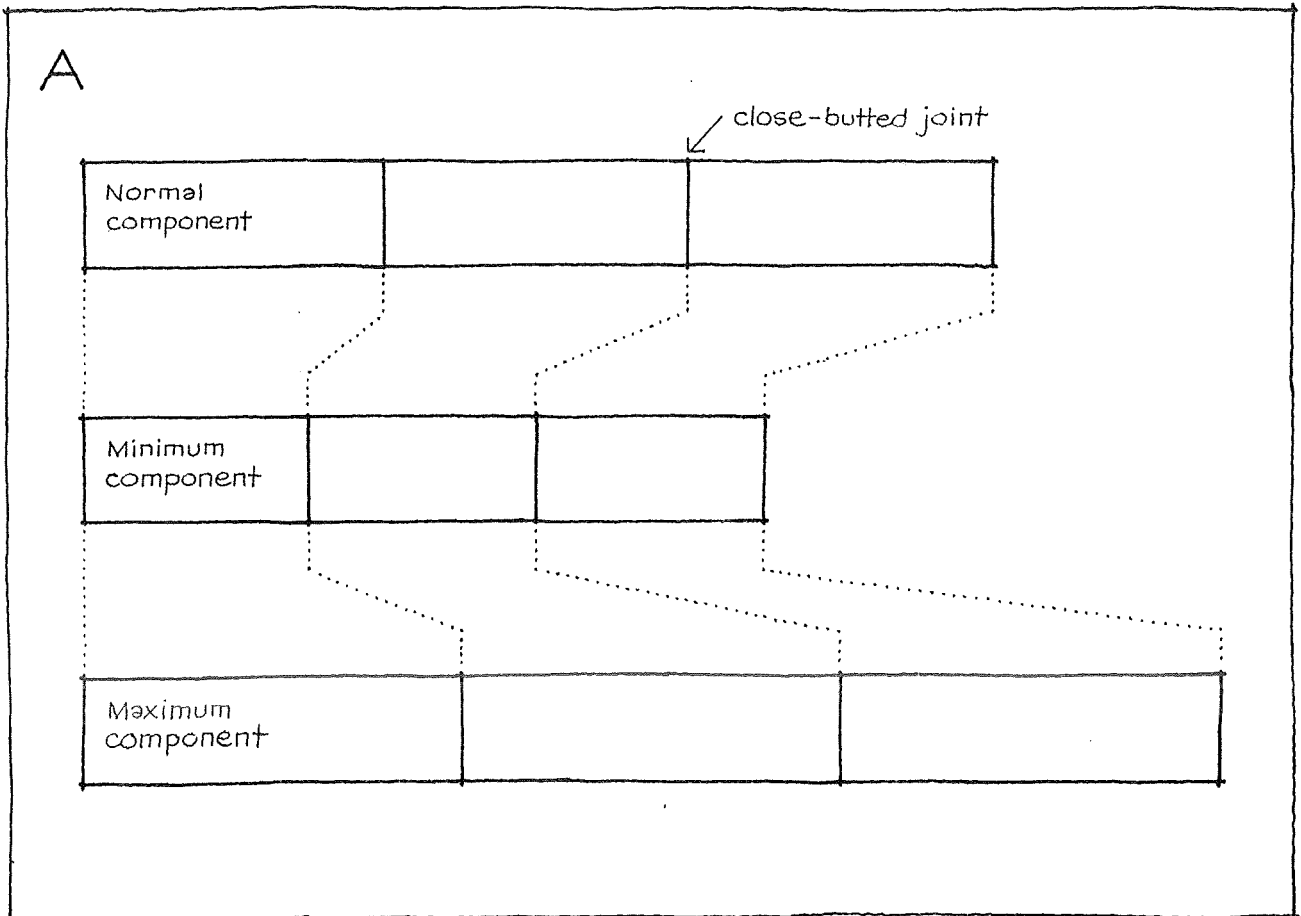

A. Third principle: No deviations can be taken up in the joint. Deviations add up.

IMG/CIB W24
 AD HOC GROUP: JOINTS
 E-314(018)KB. 740303

Example:

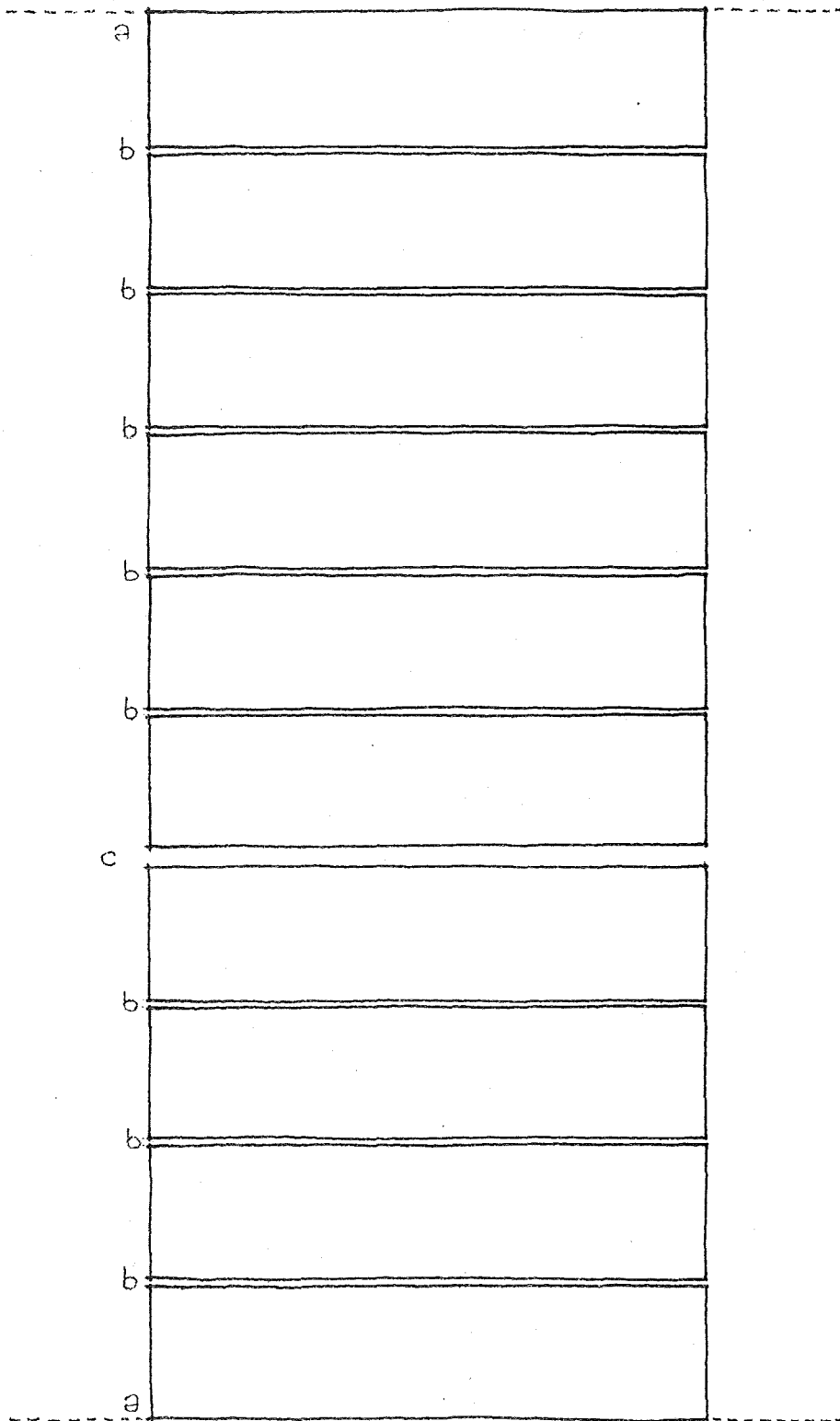

Positioning of floor components across a building.
Positioning critical at facades (a). Normal joints (b)
kept narrow to become selfshuttering. Excess deviations
taken up in one joint (c).

IMG/CIB W 24
AD HOC GROUP: JOINTS
E-314 (019) JMP. 740303

ORDER OF PLACING

The order of placing the components may be established by the geometry of the components and joints, but other reasons may be decisive as well, for example ease of (visual) adjustment, erection technique or climatic conditions.

Obviously, it is advantageous if the order of placing is free. Any ties between components involving order of placing means that the rejection of a faulty component leads to a slow-down, possibly a stop, in erection. The planning of erection technique and - sequence is also easier, if the geometry has not established an order of placing. However, technological reasons may make a definite order of placing acceptable:

Stacking is a well-known procedure. The lowest components come first. The order is a "one way" system. So is the laying of roof tiles, or the placing of some types of floor components. Close-butted joints or the like will usually establish a definite order of placing, but it may be a "left to right as well as right to left" system, as is the case with kitchen cabinets.

Finally, the almost "impossible" system has been inadvertently designed by many "inexperienced" consultants.

The order of placing can have far reaching consequences, as the following example illustrates:

Design of the facade systems involves careful consideration of the relation between climatic conditions, erection technique, order of placing, and the cladding system (possibly boiled down to finding the right position of the facade joints). The order of placing components etc. is on days with heavy frost: Placing of walls, placing of floors, placing of facades, temporary heating of rooms that grouting of floor-, wall-, and facade joints can take place one or two days later. After another day or two with temporary heating, the erection can begin on the storey above. This procedure is feasible with the left system X whereas system Y may complicate matters, or even make the order of erection "impossible".

Please
compare
text with
fig. 7.3

In system Y the spandrels are attached to the walls: The spandrel A is supported by wall C, but wall C is erected after temporary heating of room B and grouting of the corresponding joints. The temporary heating cannot be established before the facade is closed - which requires the spandrel A to be in position for closing room B and for support of the row of windows.

The vicious circle ("impossible" order of erection) can be broken:

- a) by using spandrels of type D in all storeys, combined with window components from spandrel to ceiling (the window itself may be lower, if the component incorporates a closed part between the ceiling and the actual window).
- b) by the use of "temporary facades", from spandrel to ceiling.
- c) by an erection technique allowing all (or several) storeys to be erected before the joints must be grouted.

The general conclusion, naturally, is to aim at the free condition, but in practice this rarely occurs. Therefore, the second best choice is that of a feasible, well thought out, sequence of assembly (including every small operation). If this is carried out methodically, then at least the impossible situation will be avoided.

(Floor components)

A

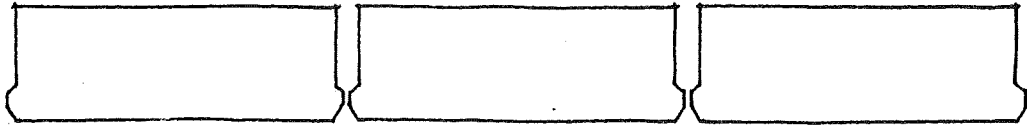

B

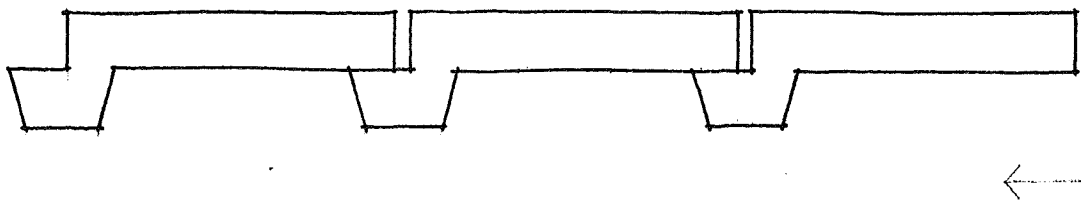

Example:

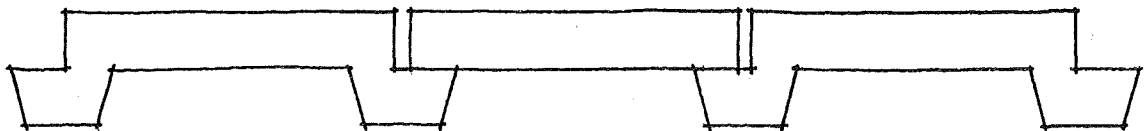

A. Order is free (unless order is imposed by lifting gear).
B. Order is right-to-left.
Example: A+B; ribbed floor components placed first (free order) slabs later (also free order).

IMG/CIB W24
AD HOC GROUP: JOINTS
E-314(020)JMP. 740303

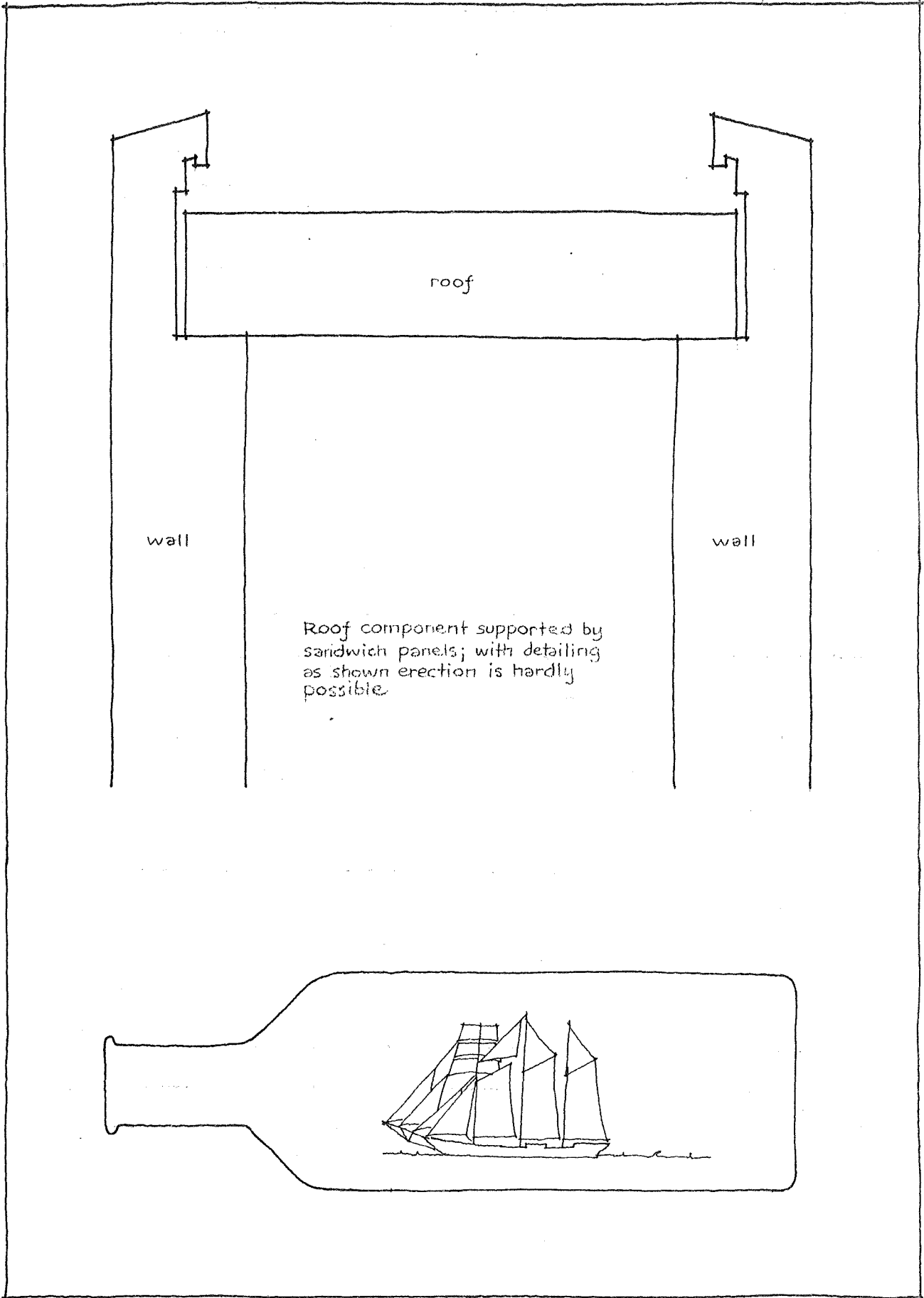

The "impossible" order of placing is too often seen in sketch-designs.

IMG/CIB W 24
AD HOC GROUP: JOINTS
E-314(021)JMP. 740303

Example:

SYSTEM X

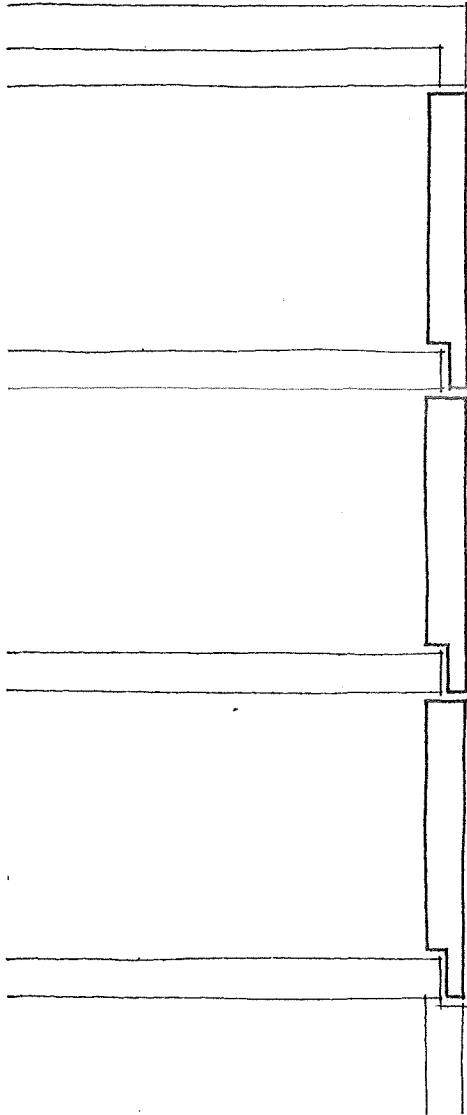

Facade system:
Room-sized sandwich-panels
with fill-in windows (windows
incorporated inside the panels)

SYSTEM Y

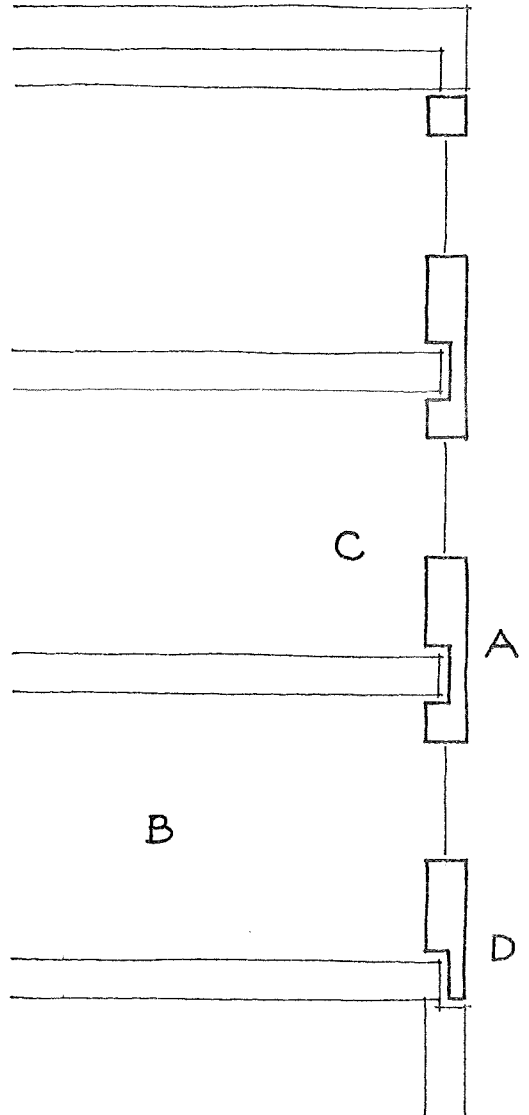

Facade system:
Spandrels and row of
windows.

Both systems are feasible, but the spandrel system becomes almost "impossible" in winter.

JOINTING PRODUCT

A main idea behind the use of components is to have as much work as possible moved from the building site to workshops and factories where many conditions are more easy to control.

This approach logically leads to considering joints in the same way: Work operations on the site - to assemble components - should preferably be few and easy to carry out.

To this may be added the fact that technological developments in component manufacture have reached such levels that assembly of components often constitute greater problems than their manufacture.

If the above argument were to be carried to its extreme, the indication would be that joints should be moved away from where building elements meet. This would allow the complicated junctions to be made as prefabricated components and "in-fills" and building site operations would become simpler. It is possible to find examples in practice of systems which rely upon the use of prefabricated junctions and simple in-fill sections (especially in plastics, metals, and wood - for exhibition stands and space structures) but as a general approach this solution has not yet proved to be feasible on any larger scale.

The best possibilities for application of the principle seem to occur where cheap extrusion processes can provide system components in standard sections and the main remaining problem therefore, is that of joining such components.

A more generally applicable approach to solving the problem of jointing by means of jointing products would seem to be the following - stated in descending order of desirability:

Fig. 8.1

1. The joint is established automatically through assembly of components which have needed no special design or preparation for the assembly in question.
(Examples: Dry rubble stone wall construction or pavements made with close-butted bricks)
2. Component interfaces have been prepared for assembly, viz. through profiling or adaptors, so that jointing may be established automatically through assembly of components.
(Example: Flooring boards with tongue-and-groove)
3. The joint is established by one jointing product being introduced where two positioned components meet.
(Examples: A gasket which establishes a two-stage joint between facade components; most of the covering strips which are applied mainly for visual reasons; some self-adhesive weather-stripping or tapes applied to provide tightness)
4. The joint is established by two or more jointing products being introduced where two positioned components meet.
(Examples: The majority of joints between primary building components like facade components, load bearing wall components, roofing components, and partition components; also at the majority of joints between unlike components, viz. door-to-wall or window-to-wall)

It follows from the above that there seems to be room for considerable improvement of quite a few of the joints which are today widely used. It also follows that the use of unformed jointing products is - in principle - less desirable. Such products, like mortar and mastics, may well be applicable, but their use implies a certain amount of extra work to be done in situ and possibly also requires better control of work quality.

The descending order of desirability indicated through the above four-point listing among other things indicates that further exploration of the possibilities for developing "automatic" joints would be desirable.

Quite a few joints of this kind are already well known. To name but a few there are magnetic locks for kitchen cabinet doors, inter-locking joints for floor boards, and the variety of new joints developed for pipe installations.

A special problem is often constituted by the exacting performance requirements met with in connection with the building envelope (viz. joining of facade components). For reasons which have nothing to do, primarily, with the geometry of joints, performance requirements will often lead to the use of rather complicated two-stage joints. But also in this case the above four-point listing holds true - to wit that some joint designs of this kind have recently moved up on the list (the finned, hollow gasket, which can be installed in one operation, substitutes for a number of jointing products and operations which were previously necessary).

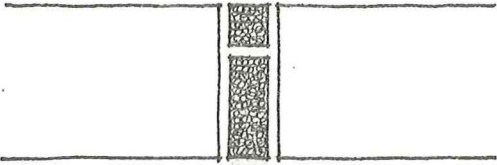
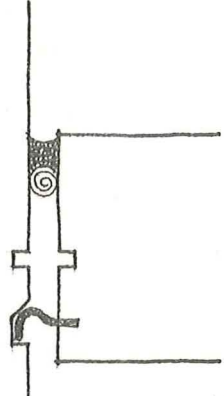
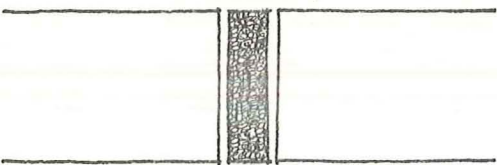
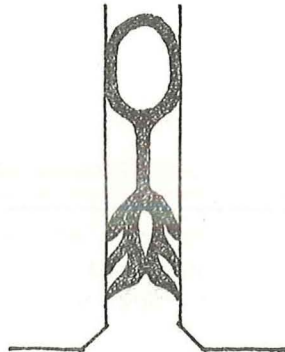
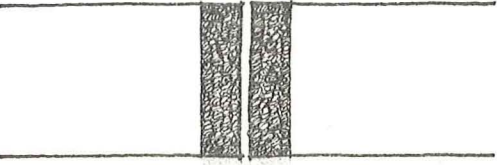
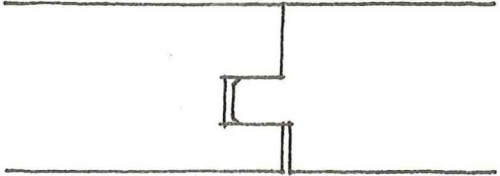
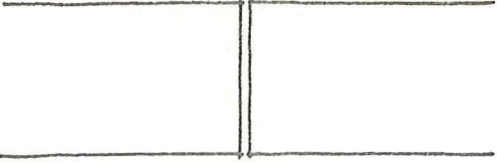
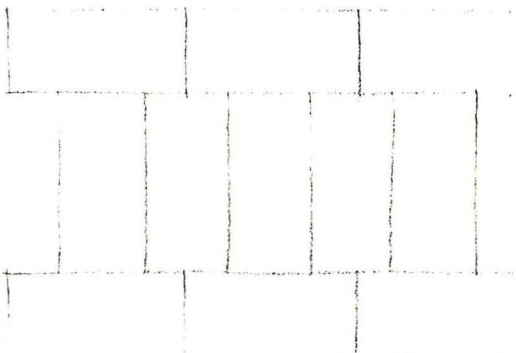
Principles	Examples
<p>1</p> 	<p>Examples</p>  <p>wall to window</p>
<p>2</p> 	 <p>pat. pend. finned, hollow gasket</p>
<p>3</p> 	 <p>tongue-and-groove</p>
<p>4</p> 	 <p>brick pavement</p>

- 1: Two or more jointing products
- 2: One jointing product
- 3: No jointing product; interface profiling or adaptors
- 4: No jointing product; no treatment of interface

IMG/CIB W24
 AD HOC GROUP: JOINTS
 E-314 (023) KB. 740216

ADJUSTABILITY

Fig. 9.1

The jointing procedure may be designed so that the position of each component is easily adjustable. By this one might achieve faster erection, or savings in labour, materials, etc., or just ease of (adjustment of) positioning, for example where a number of unlike components must be connected or where corrections are necessary for visual reasons.

The means of adjustment may be part of the component or of the jointing product, or it may be a special tool (not always reusable), a special component (adaptor) or just a deliberately adjustable fixing.

In principle, adjustment can take place before, during or after placing the component. The earlier one adjust, the less one can take into account in respect of (unforeseen) deviations. A very late adjustment procedure may, however, increase costs of tools, labour, etc. The plastics gutter, attached to the structure by screws in slots, represent a fourth variant, continuously adjustable, a sort of expansion joint (to take thermal movements, creep, etc. a functional requirement). There is also a fifth variant, that of the deliberately not-adjustable joint.

Fig. 9.2

In reality, practice is complex. As an example to show this, one can take a dual function lifting bolt in the erection procedure for concrete walls and floors where one may consider the structure as a series of alternating floor and wall components with "no adjustment" joints alternating with "adjustment before erection" joints.

The floors are placed on top of the wall, and the joint is a dry, close-butted joint for speedy erection. This is a special variant of "adjustment before erection", as no adjustment is possible during or after placing of the floor component. The deviations in floor thickness are automatically added to the probably only partly adjusted deviations of the top of wall.

Before the self-shuttering joint between the floor nibs is poured, the positions of the lifting bolts are checked, and possible bent bolts are corrected. Then, the nuts on all bolts are levelled. This means that all walls are automatically placed in an almost absolute correct position, vertically and horizontally along the lower edge of the wall.

This is a typical "adjustment before erection" procedure, where adjustment takes care of all deviations from previously placed floors and walls. Theoretically, the result may be regarded as a series of walls with adjustable joints. The deviations are not added vertically, as each wall is adjusted individually. Horizontally, the deviations are closely linked as the walls are placed on top of each other, symmetrically around the bolt/reference line.

The general recommendation is that although it is desirable to have much adjustability as can easily be obtained, this must always be seen against the need for such adjustability. There is, however, under all circumstances a close tie between tolerances and adjustability.

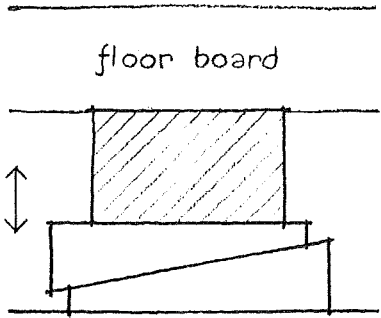
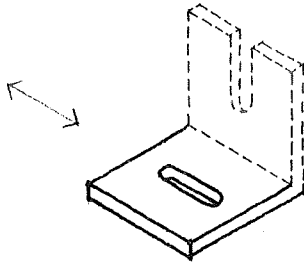
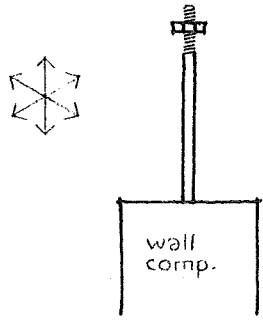
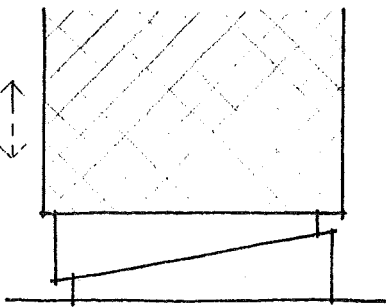
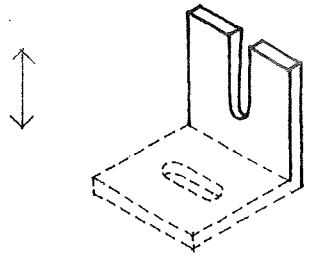
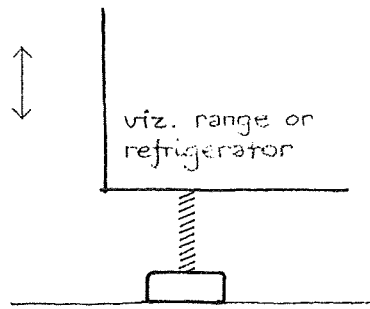
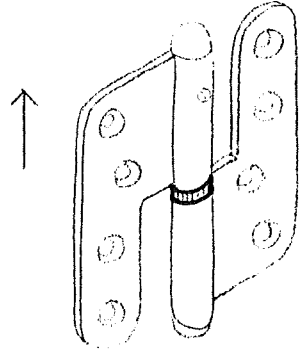
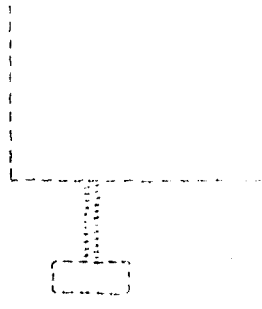
BEFORE	DURING	AFTER
<p>floor board</p>  <p>wedges under wooden joist (floor)</p>  <p>slotted fitting fixed on floor component....</p>  <p>wall comp.</p> <p>nut on threaded bolt</p>	 <p>wedges under partition component</p>  <p>.... ready for positioning of facade component</p>  <p>viz. range on refrigerator</p> <p>threaded spindle footing..</p>	 <p>metal ring in hinge</p>  <p>.... adjustable also later</p>

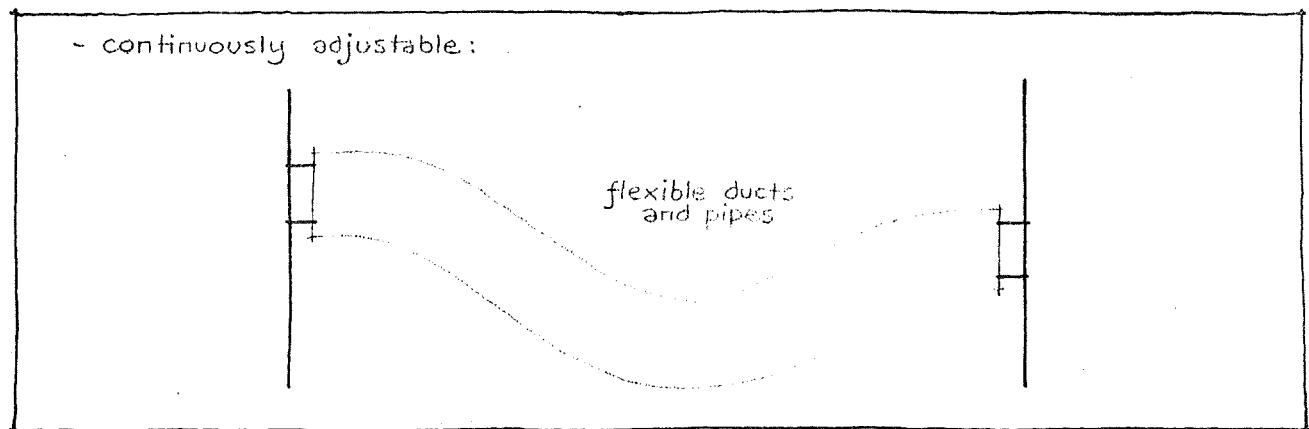

Examples only.

← → indicate main direction of adjustment.

IMG/CIB W24
 AD HOC GROUP: JOINTS
 E-314(024)KB. 74040

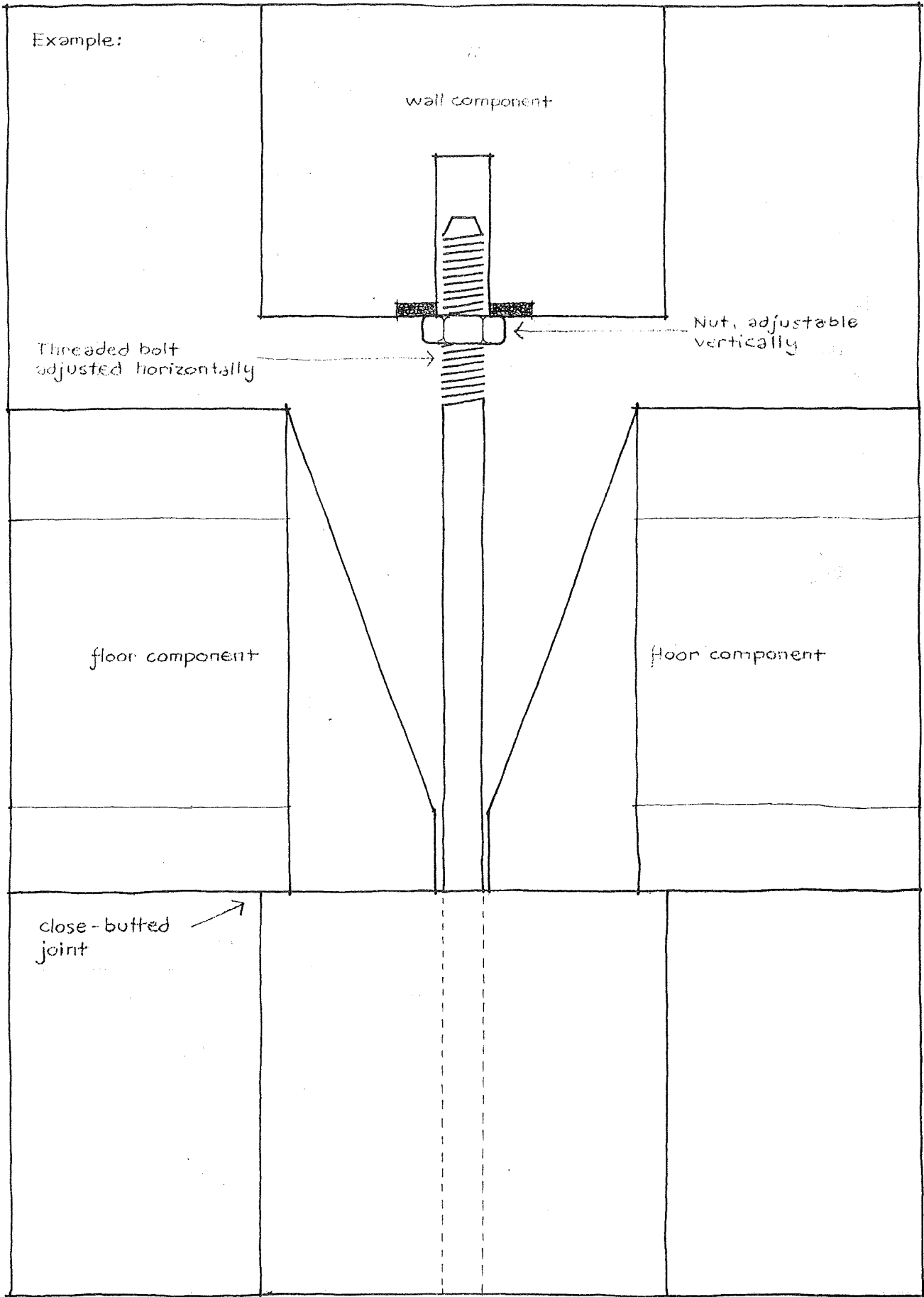

Practice may be complex: Threaded lifting bolt with nut allows accurate positioning of wall components - but accuracy of floor component surface positioning will depend upon manufacturing tolerances.

IMG/CIB W24
AD HOC GROUP: JOINTS
E-314(025) JMP 740502

EASE OF CHANGE AND REPAIR

There is much current concern with "flexible" buildings, capacity for improvement, re-usability of components and materials. The joint characteristics will to a large extent govern the possibilities for developing such features.



Joints, and particularly jointing products, will have a more-or-less predictable life. If such a life is less than that of the components being jointed, or if a short life component is being jointed to a longer life component, then the joint will need to permit demounting and reassembly or replacement. If it can be done with a minimum of effort, and without the use of special tools which may not be available at some indeterminate future date, then this is a bonus.

Fig. 10.1 Cost-in-use (covering both maintenance and replacement) over the whole life of the component-joint amalgam will determine when things should be done; the initial design should then physically permit those same things to be done.

The well-known synthetic rubber gasket with a dovetail insert shows some of the qualities ideally looked for. Provided no degradation of the section happens, then it may be un-zipped to allow a component to be replaced, it may be removed for use elsewhere, it entails no preparation of jointing surfaces nor their cleaning on reassembly. If it is not easy to repair, then it is perhaps tough enough to need repair only infrequently, and cheap enough to be thrown away and replaced when too badly damaged.

Joints needing attention during their life must be visible and accessible. Take for example a two stage joint between two pre-cast concrete panels which will need an air seal as well as a water barrier. The water barrier should be accessible from the outside, and the air seal from the inside.

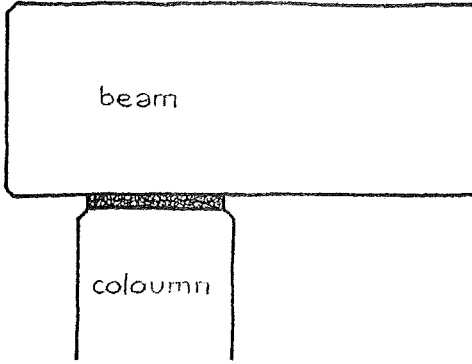
The recommendation, therefore, is that non-deteriorating (or even self-improving) joints are aimed for. Where repair is necessary or where ease of change is desirable then joints must be accessible, and must physically permit replacement or repair.

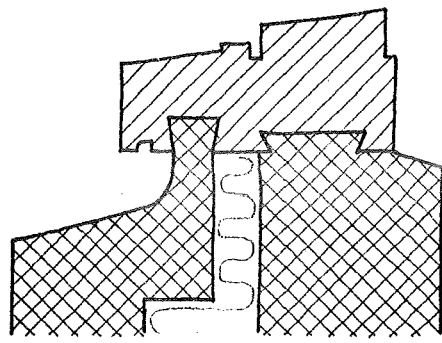
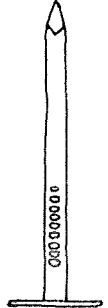
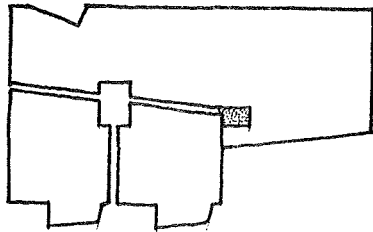
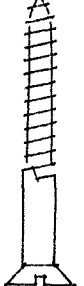
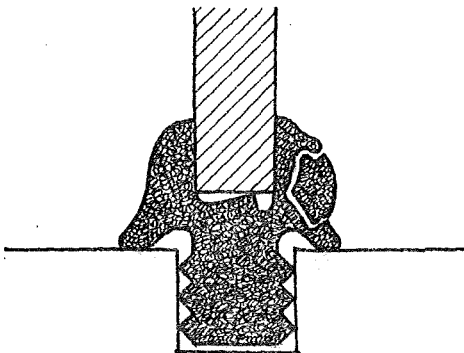
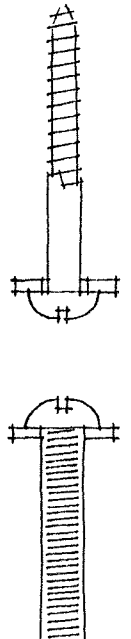
 <p>beam</p> <p>column</p>	<p>IMPOSSIBLE</p> <p>- both components and the jointing product are destroyed</p> <p>(Example: A pad between two loadbearing units)</p>	
	<p>IMPRACTICABLE</p> <p>- destroying one component or damaging both</p> <p>(Example: A wood window cast into a concrete panel)</p>	
	<p>AWKWARD</p> <p>- damaging the jointing product and possibly one component</p> <p>(Example: A wood window with a glued-in-place foamed rubber weather-strip)</p>	
	<p>EASY</p> <p>- damaging neither components nor the jointing product</p> <p>(Example: A Neoprene zipper gasket)</p>	 <p style="text-align: right;">*)</p>

*) The various types of nails and screws also have different properties in regard to ease of change and repair

VISUAL IMPACT

It is not enough that components are modular and that joints between them are technically correct. Their visual impact must also be planned or 'designed'.

Fig. 11.1 Visual co-ordination of design details like joints becomes especially important where components of various types are integrated to form greater units like rooms and buildings. In these cases the total result should also be satisfactory in an aesthetic sense.

It is naturally not possible to predict the kind of visual impact which may be desired in specific cases, but some guidelines as to how haphazard visual impact may be avoided are given in the following:

- Fig. 11.2 1. Sketches of joint designs should be done in a sufficiently large scale (at least 1:5) so as to make judgment of visual impact possible. (Example: A room with a window and a nearby door. Except on a small scale drawing, the visual impact of the heights may not be the modular sizes. Instead, it can be the top of the leaf of the door or of the moulding over the door, and the top of the opening of the window in the exterior wall.
- Fig. 11.3 2. The visual impact of joint intersections - especially between joints of different design - should be clarified, viz. by means of large scale perspective or axonometric sketches. (Example: A curtain wall facade and a heavy loadbearing gable are both built with components. In this case the joint design for each type of wall will normally be strongly influenced by functional requirements (tightness against rain and wind etc.). This makes it desirable to consider joint intersections - viz. of horizontal joints at building corners - at an early stage, because changes later, to obtain a desired visual impact, may be difficult to make and may occasion nearly unforeseeable ramifications.

Additionally, it may in certain cases be desirable to consider the following guidelines:

- Fig. 11.4 3. Changes in a technically correct joint to obtain a desired visual impact should only be proposed after due consideration. In quite a few cases it may thus be found that the desired visual impact can more easily be obtained by making changes in the component design.
- Fig. 11.5 4. Through proper joint design it is often possible to disguise or mask undesirable visual impacts stemming from dimensional deviations. Thus narrower joints will often mean more appreciable deviations, while any kind of so called 'shadow joint' will help to disguise deviations.

In many cases it is desirable to look at several joint designs simultaneously (viz. those appearing in a room). Even when each joint has been carefully designed, also at intersections, there may still occur undesirable visual impacts.

Fig. 11.6 As but one example, there may not be a free choice as to where partitions are positioned in relation to joints between ceiling components.

In most cases the partition may either be put symmetrically under the joint between ceiling components, which is thereby hidden, or it may be put so far from a joint between ceiling components that misalignment of joints between ceiling components themselves and between ceiling and partition cannot easily be observed.

On the other hand a positioning of the partition so that it has one side aligned with the joint between ceiling components is often not recommended, because dimensional deviations (viz. misalignment) would tend to become very clearly visible.

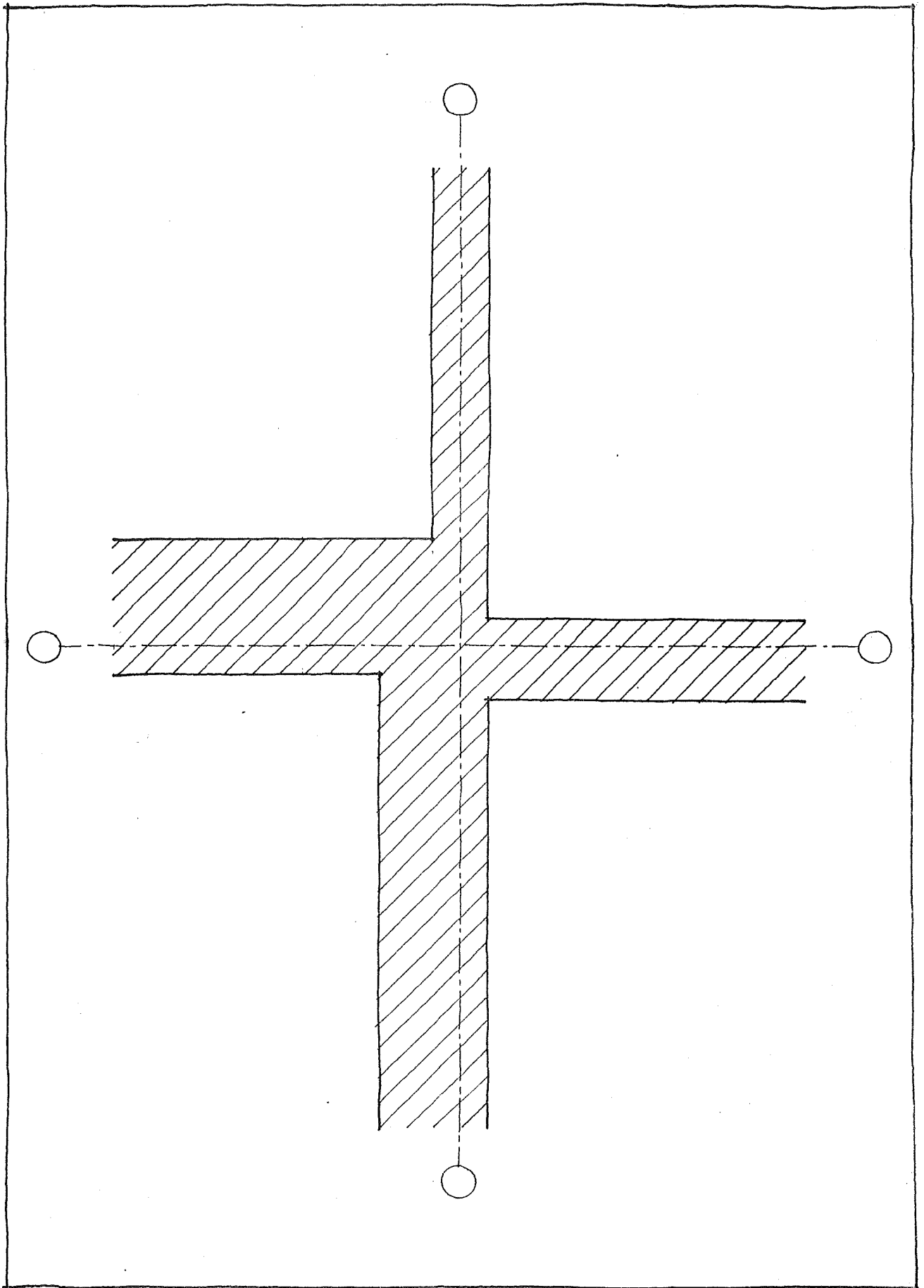

Haphazard visual impact, viz. at joint intersection of four different joint widths between facade components.

IMG/CIB W24
AD HOC GROUP: JOINTS
E-314 (027) KB 740201

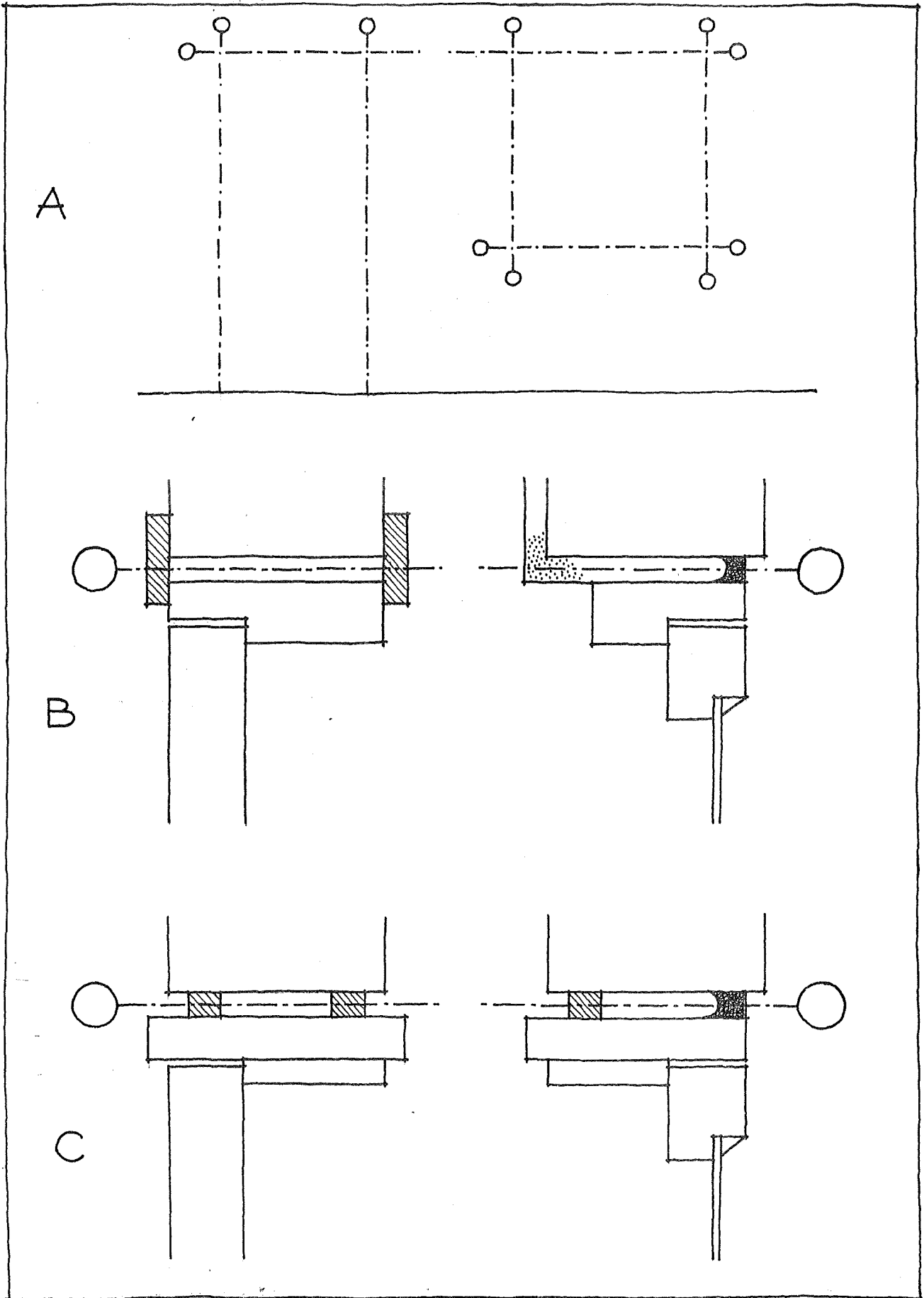

A: Both internal door and window are modular.
But on a larger scale drawing:
B: Haphazard visual impact
C: Planned visual impact.

IMG / CIB W24
AD HOC GROUP: JOINTS
E-314 (028) KB 740201

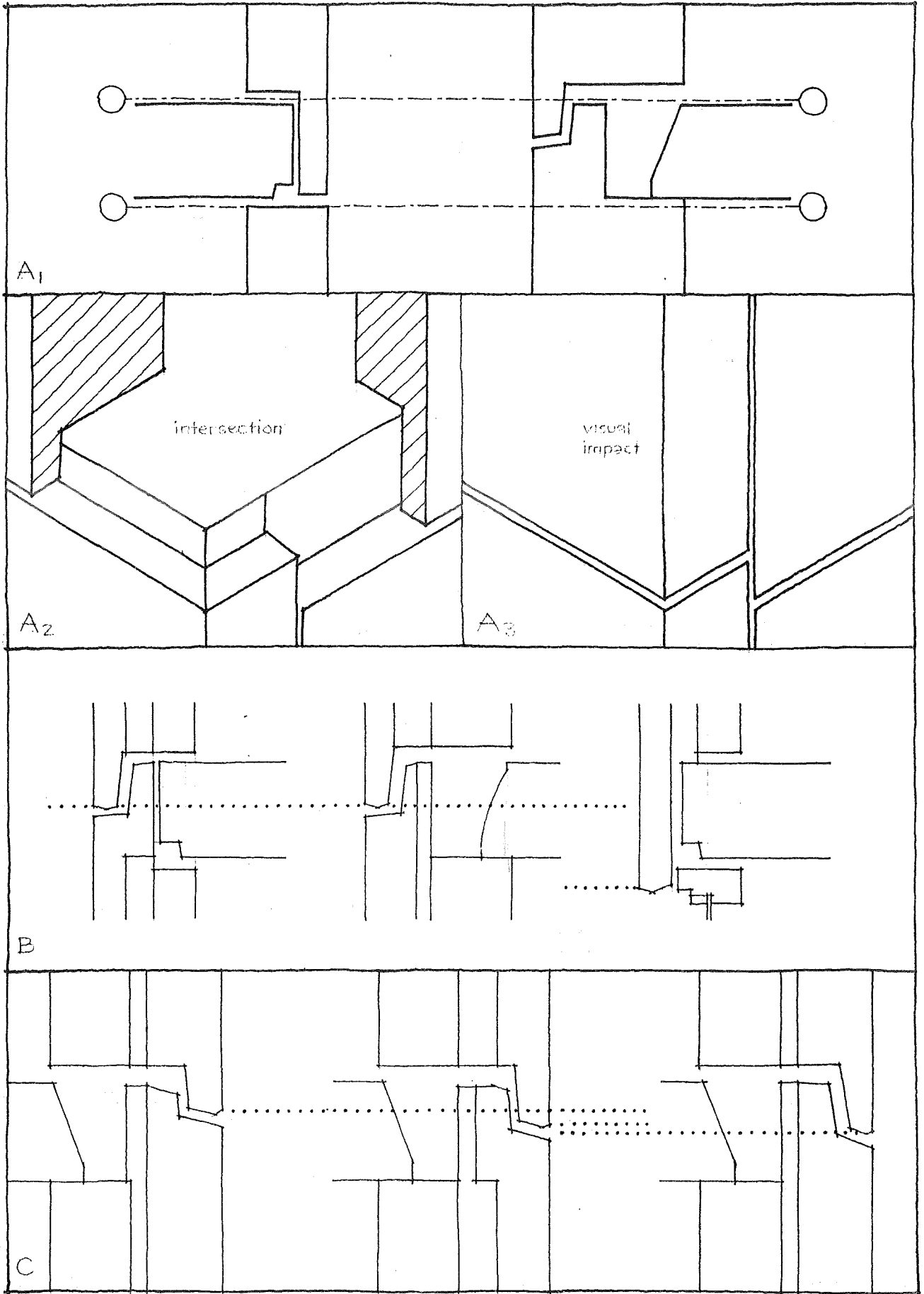

A: Intersection of light facade and heavy gable.
B: Some firms offer visually co-ordinated details
C: Lack of co-ordination between firms.

IMG/CIB W24
AD HOC GROUP: JOINTS
E-314(029) KB 740202

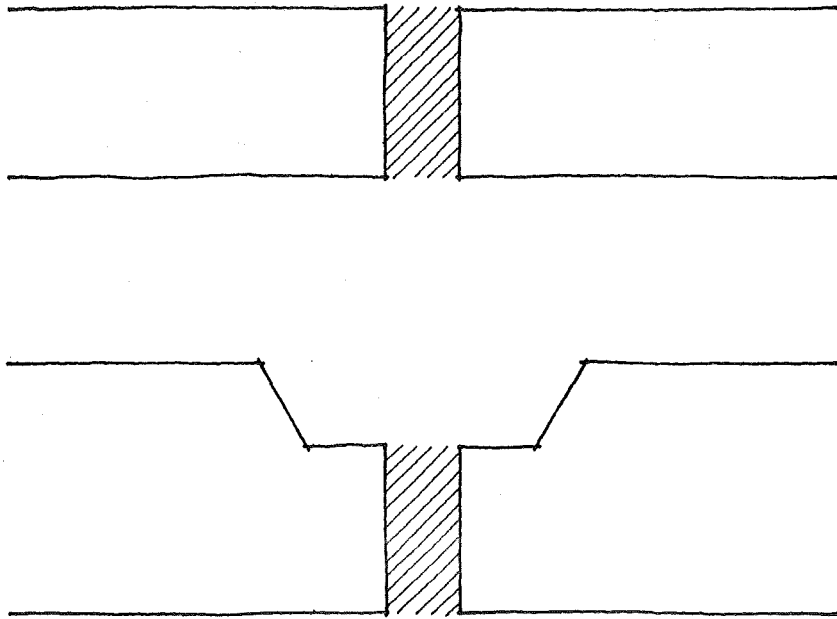

Examples:

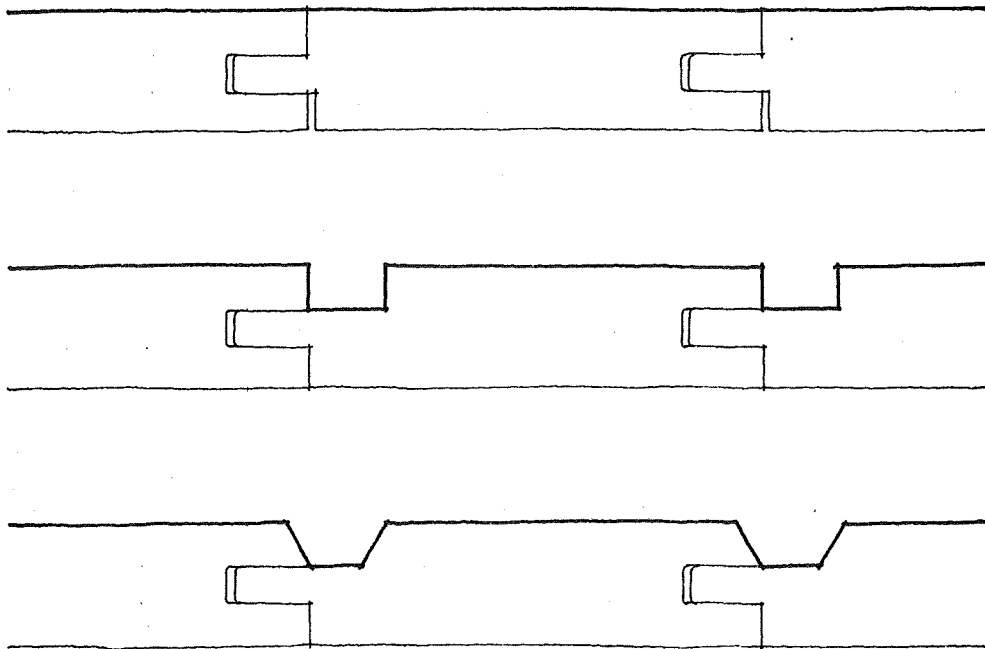

To obtain a desired visual impact
changing component design is often easier
than changing joint design.

IMG/CIB W24
AD HOC GROUP: JOINTS
E-314 (030) KB 740203

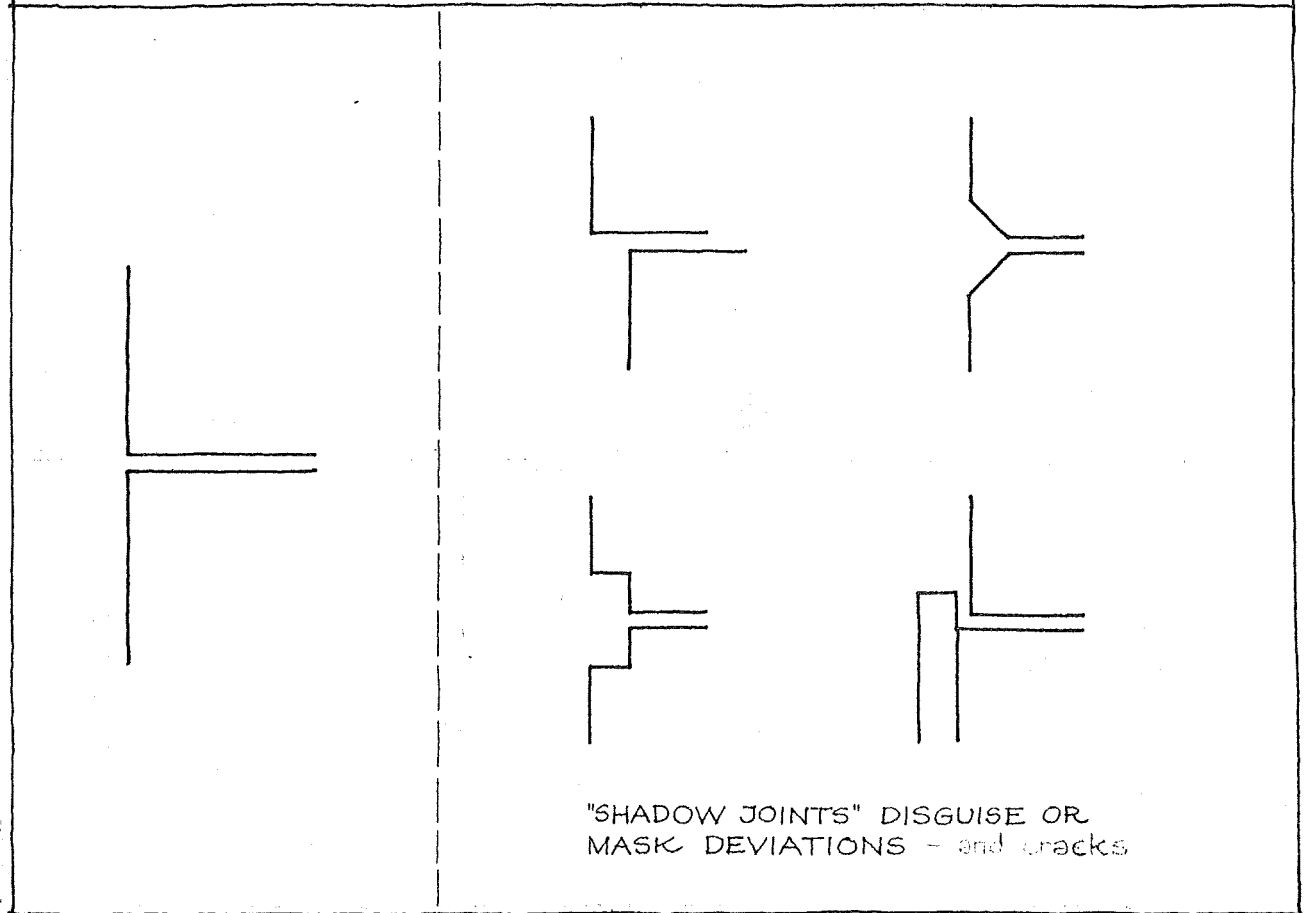
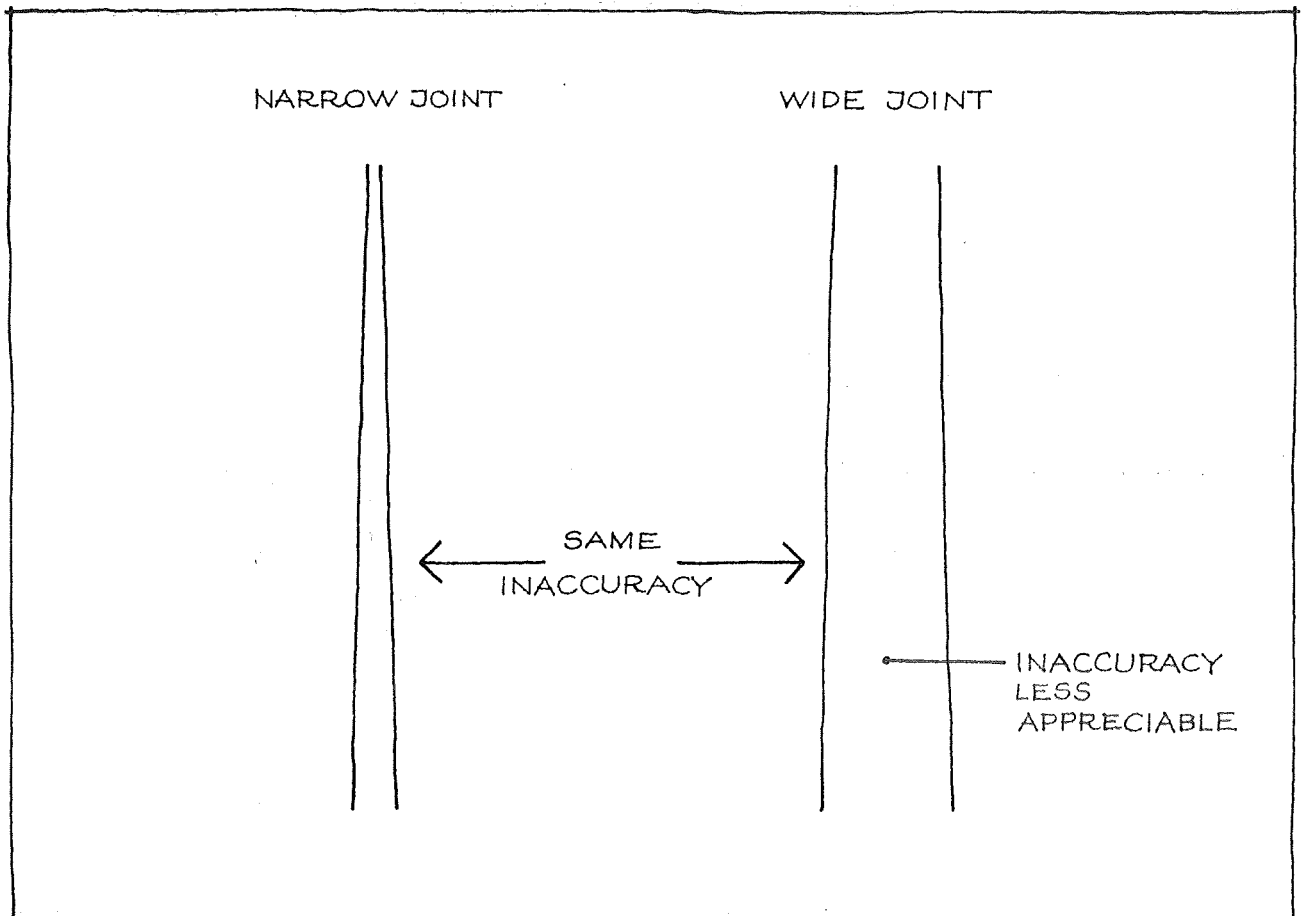

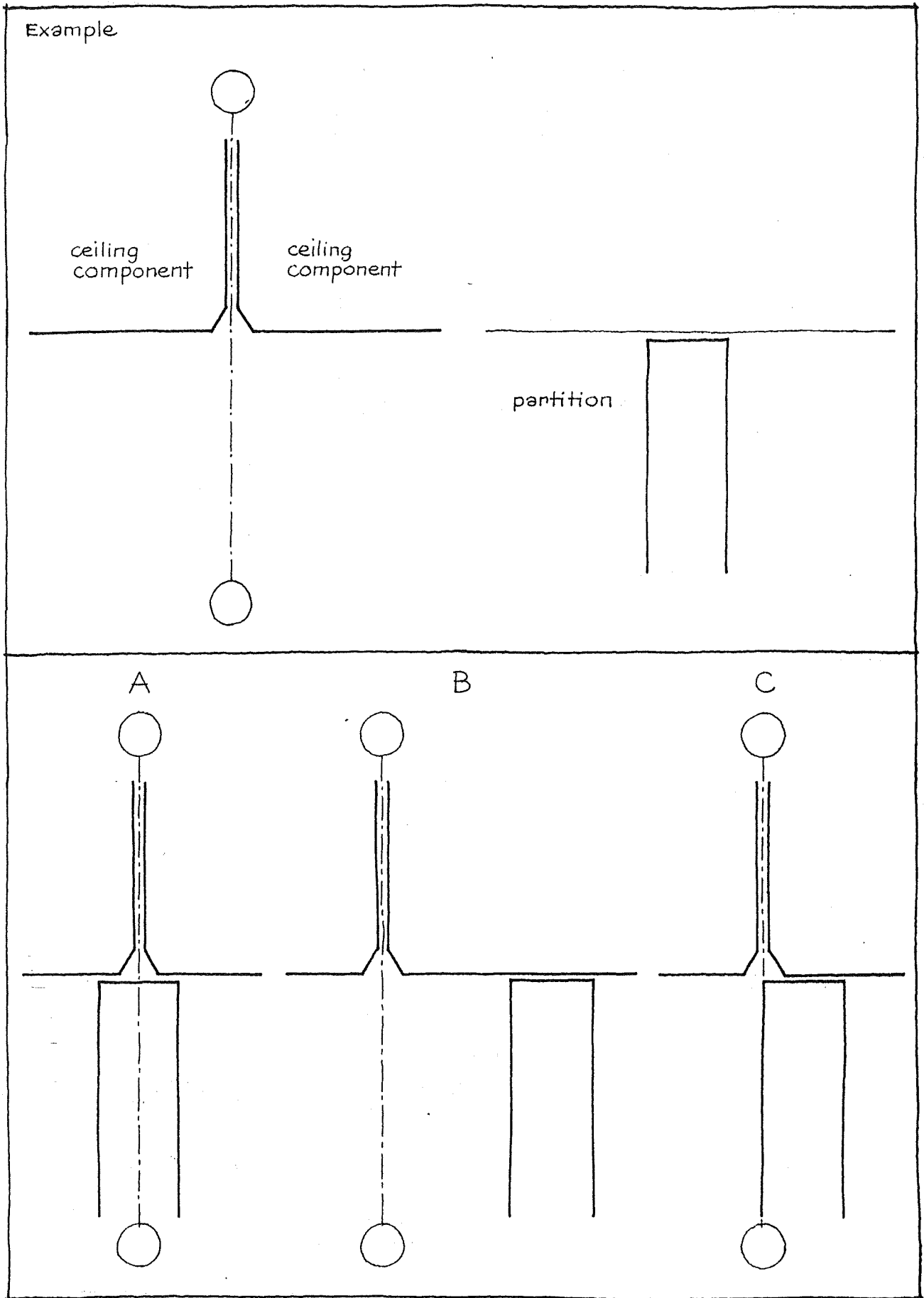

- A: ceiling joint hidden
- B: eventual misalignment not easily observable
- C: any misalignment will show

IMG/CIB W24
AD HOC GROUP: JOINTS
E-314 (032) KB. 740203

FORTEGNELSE OVER FORELÆSNINGSNOTATER, UDGIVET AF
 INSTITUTTET FOR HUSBYGNING, DANMARKS TEKNISKE HØJSKOLE

Nr.	Forfatter	Titel	
1		Ikke benyttet	
2	Stålby, Jens E.	Jordskælvspåvirkninger i husbygningskonstruktioner, 1969	
3		Ikke benyttet	
4	Munch-Petersen, Johs.F.	Facadeelementer, 1970 (revideret, erstattet af nr.30)	udgået
5	Guntofte, Keld	Tolerancer, 1971	
6	Lundsgaard, H.	Brandteknik under projektering, 1971	udgået
7	Linnemann Bech, Paul	Afstivende systemer, 1971	udgået
8	Linnemann Bech, Paul	Bærende systemer, 1971	udgået
9	Munch-Petersen, Johs.F.	Philosophy of Design, 1971 (revideret, erstattet af nr.19)	
10	Munch-Petersen, Johs.F.	Varmeisolering til Hus-Behov, 1971	
11	Munch-Petersen, Johs.F.	Pris og produktivitet, 1971	
12	Munch-Petersen, Johs.F.	Statik til Hus-Behov, 1971 (revideret, erstattet af nr.26)	
13	Guntofte, Keld	Konstruktionssamlinger, 1971	
14	Hilbert, Niels-Ole og Stokbæk, K.	Betonelementproduktion, 1971	
15	Linnemann Bech, Paul og Nielsen, Jørgen	Elementær skivestatik, 1971	
16	Munch-Petersen, Johs.F.	System Building Design Philosophy, 1972, (revideret, erstattet af nr. 19)	udgået
17	Guntofte, Keld	Structural Problems in System Building, 1972	
18	Østergaard, Poul	Bygningsbrandlovgivning	udgået
19	Munch-Petersen, Johs.F.	System Building Design Philosophy, 1972 (revideret udgave)	
20	Jakobsen, Torben	Bygningsmaterialers brandtekni- ske egenskaber, 1972	udgået

Nr.	Forfatter	Titel	
21		Ikke benyttet	
22	Pedersen, Erik	Brandteknisk vurdering af ventilationsanlæg, 1973	
23	Jensen, Bjarne Chr.	Branddimensionering af konstruktionselementer i træ, 1973	
24		Ikke benyttet	
25		Modul BBC-blade, Dæk- og væg-elementer fra Modulbeton, 1972	
26	Munch-Petersen, Johs.F.	Statik til Hus-Behov, 1972 (revideret udgave)	
27	Guntofte, Keld	Brochurer, 1972	
28	Munch-Petersen, Johs.F.	Byggemetoder, 1972	
29	Linnemann Bech, Paul	Bærende systemer, 1972	udgået
30	Munch-Petersen, Johs.F.	Facadeelementer, 1973 (revideret udgave)	
31	Borchersen, Egil	Skivebygninger 1: Statik, 1973 (revideret, erstattet af nr. 38)	
32	Uddrag af SBI-anv.82	Skivebygninger 2: Beregningsmodeller, 1973	udgået
33	Uddrag af SBI-anv.82	Skivebygninger 3: Figurer, 1973	udgået
34	Uddrag af SBI-anv.82	Skivebygninger 4: Eksempler, 1973	
35	Haagentoft, Jens H.	Byggelovgivning, 1973	
36	Jessen, Richard	Murede huse, 1974.	
37	Larsen, Henning	Faserne i bygningsplanlægning, 1974.	
38	Borchersen, Egil	Skivebygninger 1: Statisk bestemte skivekonstruktioner, 1974	
39	Jessen, Richard	Etageboligen, 1974	
40	Blach, Klaus, Henry W. Harrison, Johs.F. Munch-Petersen	Geometry of Joints, 1975	

